

Rotary Cutters

RCR2596, RCR2510 and RCRM2510

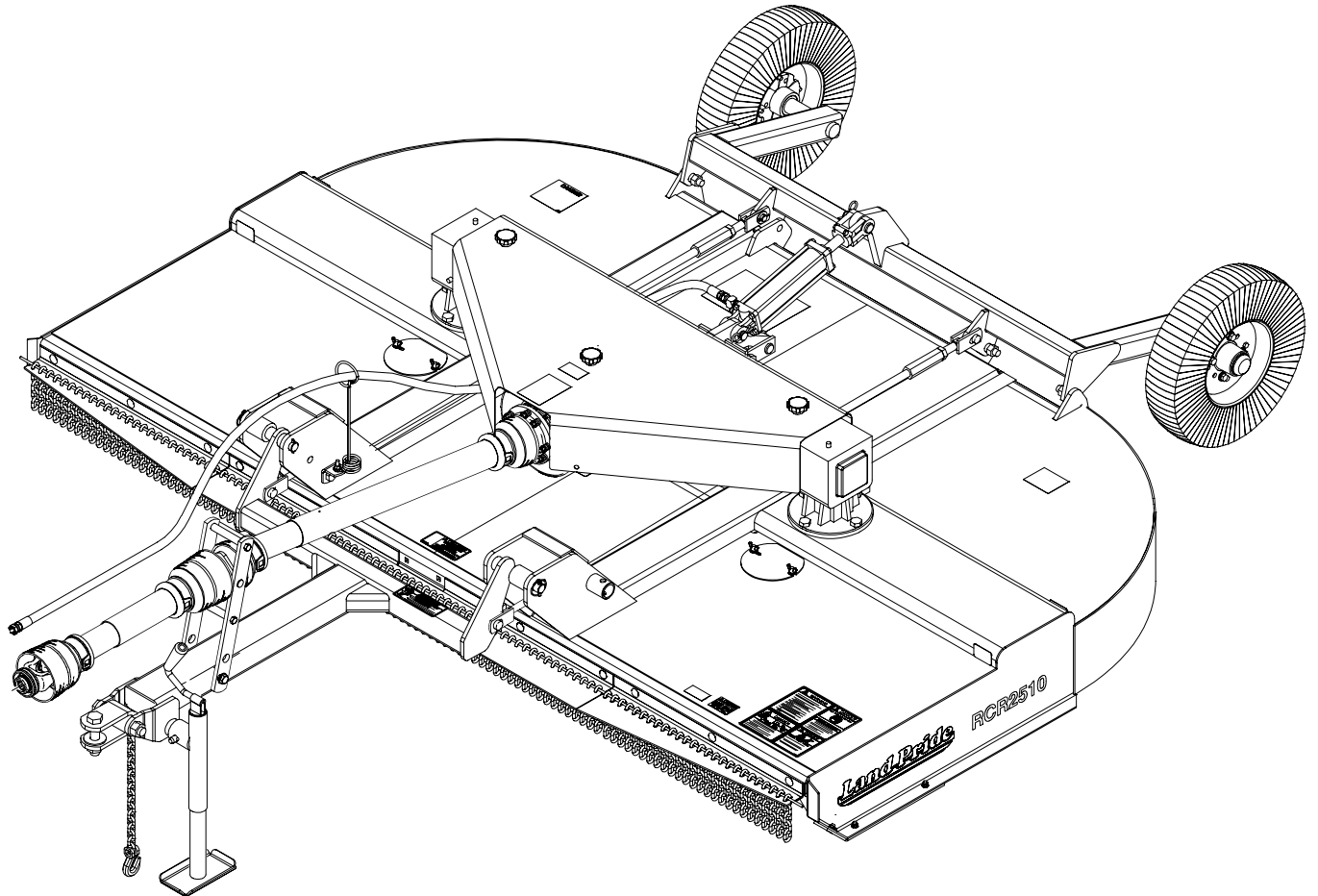

22288

312-753M Operator's Manual



Read the Operator's Manual entirely. When you see this symbol, the subsequent instructions and warnings are serious - follow without exception. Your life and the lives of others depend on it!

© Copyright 2008 Printed 5/09/08

Cover photo may show optional equipment not supplied with standard unit.



Important Safety Information	1	Section 2: Adjustments	22
Safety at All Times	1	Leveling Procedure	22
Look For The Safety Alert Symbol	1	Lift-Type Cutter	22
Safety Labels	4	Pull-Type Cutter	22
Introduction	8	Cutting Height Adjustment	23
Application	8	Lift-Type Cutter	23
Using This Manual	8	Pull-Type Cutter	23
Terminology	8	Section 3: Operating Procedures	24
Definitions	8	Operating Check List	24
Owner Assistance	8	Transporting the Cutter	24
Serial Number Plate	8	Un-hooking the Cutter	24
Further Assistance	9	Cutting Instructions	25
Section 1: Assembly and Set-Up	10	Turning Angles for Pull-Type Cutters	25
Tractor Requirements	10	Crossing Steep Ditches & Banks	26
Weight & Horsepower	10	General Operating Instructions	26
PTO Type & Speed	10	Section 4: Maintenance & Lubrication	28
Pull-Type Hitch	10	Maintenance	28
3-Point Hitch	10	Service Cutting Blades	28
Dealer Preparations	10	Driveline Protection	29
Gearbox Vent Plug	11	Clutch Run-In	29
Lift-Type Cutter	11	Clutch Disassembly	30
Hitch Assembly	11	Clutch Inspection	30
Driveline Installation	11	Clutch Assembly	30
Pull-Type Cutter	12	Flex Couplers	31
Hitch Assembly	12	Skid Shoe Maintenance	31
Equal Angle Driveline Installation	13	Tractor Maintenance	31
Constant Velocity Driveline Installation	14	Storage Instructions	31
Chain Safety Shields (Optional)	15	Lubrication Points	32
Front Chain Shields (RCR2596)	15	Tailwheel Spindle Tube	32
Front Chain Shields (RCR(M)2510)	15	Tailwheel Hub	32
Rear Chain Shield	15	Gearbox & T-Box	32
Rubber Safety Shields (Optional)	16	Driveline U-Joints	33
Front Rubber Shields (RCR2596)	16	Driveline	33
Front Rubber Shields (RCR(M)2510)	16	Constant Velocity Driveline	33
Rear Rubber Shield	16	Flex Coupler	33
3-Point Tractor Hook-Up	17	Pillow Bearing (Pull-Type Cutter)	34
Driveline Hook-up	17	Ratchet Jack	34
Checking Driveline Minimum Length	18	Section 5 Specifications & Capacities	35
Pull-Type Tractor Hook-Up	20	Section 6: Features & Benefits	36
Safety Chains	20	Section 7: Troubleshooting	37
Pull-Type Tractor Un-Hook	20	Section 8: Appendix	38
Check Chains, 3-Point Lift-Type Cutters	21	Torque Values Chart for Common Bolt Sizes	38
		Tire Inflation Chart	38
		Warranty	39

© Copyright 2008 All rights Reserved

Land Pride provides this publication "as is" without warranty of any kind, either expressed or implied. While every precaution has been taken in the preparation of this manual, Land Pride assumes no responsibility for errors or omissions. Neither is any liability assumed for damages resulting from the use of the information contained herein. Land Pride reserves the right to revise and improve its products as it sees fit. This publication describes the state of this product at the time of its publication, and may not reflect the product in the future.

Land Pride is a registered trademark.

All other brands and product names are trademarks or registered trademarks of their respective holders.

Printed in the United States of America.

Important Safety Information

These are common practices that may or may not be applicable to the products described in this manual.

Safety at All Times

Thoroughly read and understand the instructions given in this manual before operation. Refer to the "Safety Label" section, read all instructions noted on them.

Do not allow anyone to operate this equipment who has not fully read and comprehended this manual and who has not been properly trained in the safe operation of the equipment.

- ▲ Operator should be familiar with all functions of the unit.
- ▲ Operate implement from the driver's seat only.
- ▲ Make sure all guards and shields are in place and secured before operating the implement.
- ▲ Do not leave tractor or implement unattended with engine running.
- ▲ Dismounting from a moving tractor could cause serious injury or death.
- ▲ Do not stand between the tractor and implement during hitching.
- ▲ Keep hands, feet, and clothing away from power-driven parts.
- ▲ Wear snug fitting clothing to avoid entanglement with moving parts.
- ▲ Watch out for wires, trees, etc., when raising implement. Make sure all persons are clear of working area.
- ▲ Turning tractor too tight may cause implement to ride up on wheels. This could result in injury or equipment damage.

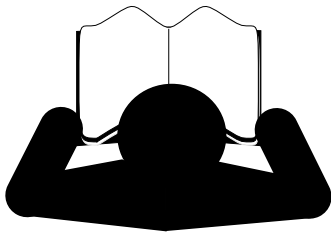

Look For The Safety Alert Symbol

The SAFETY ALERT SYMBOL indicates there is a potential hazard to personal safety involved and extra safety precaution must be taken. When you see this symbol, be alert and carefully read the message that follows it. In addition to design and configuration of equipment, hazard control and accident prevention are dependent upon the awareness, concern, prudence and proper training of personnel involved in the operation, transport, maintenance and storage of equipment.

Be Aware of Signal Words

A Signal word designates a degree or level of hazard seriousness. The signal words are:

DANGER

Indicates an imminently hazardous situation which, if not avoided, will result in death or serious injury. This signal word is limited to the most extreme situations, typically for machine components that, for functional purposes, cannot be guarded.

WARNING

Indicates a potentially hazardous situation which, if not avoided, could result in death or serious injury, and includes hazards that are exposed when guards are removed. It may also be used to alert against unsafe practices.

CAUTION

Indicates a potentially hazardous situation which, if not avoided, may result in minor or moderate injury. It may also be used to alert against unsafe practices.

For Your Protection

- ▲ Thoroughly read and understand the "Safety Label" section, read all instructions noted on them.

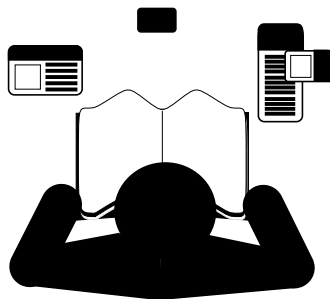

Shutdown and Storage

- ▲ Lower machine to ground, put tractor in park, turn off engine, and remove the key.
- ▲ Detach and store implements in a area where children normally do not play. Secure implement by using blocks and supports.

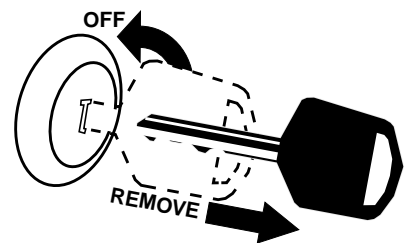

Important Safety Information

These are common practices that may or may not be applicable to the products described in this manual.

Use Safety Lights and Devices

- ▲ Slow moving tractors, self-propelled equipment, and towed implements can create a hazard when driven on public roads. They are difficult to see, especially at night.
- ▲ Flashing warning lights and turn signals are recommended whenever driving on public roads. Use lights and devices provided with implement.

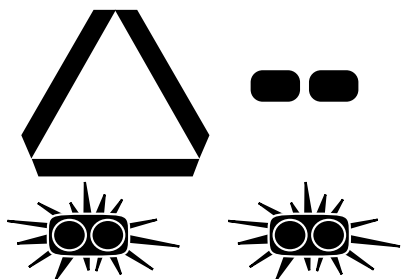

Transport Machinery Safely

- ▲ Comply with state and local laws.
- ▲ Maximum transport speed for implement is 20 mph. **DO NOT EXCEED.** Never travel at a speed which does not allow adequate control of steering and stopping. Some rough terrain require a slower speed.
- ▲ Sudden braking can cause a towed load to swerve and upset. Reduce speed if towed load is not equipped with brakes.

- ▲ Use the following maximum speed - tow load weight ratios as a guideline:
20 mph when weight is less than or equal to the weight of tractor.
10 mph when weight is double the weight of tractor.
IMPORTANT: Do not tow a load that is more than double the weight of tractor.

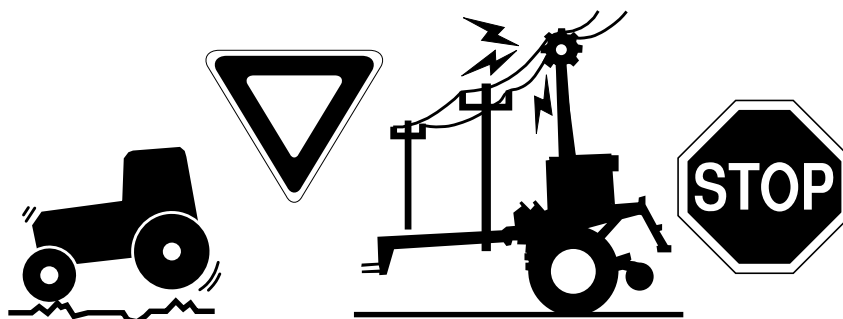

Use A Safety Chain

- ▲ A safety chain will help control drawn machinery should it separate from the tractor drawbar.
- ▲ Use a chain with the strength rating equal to or greater than the gross weight of the towed machinery.
- ▲ Attach the chain to the tractor drawbar support or other specified anchor location. Allow only enough slack in the chain to permit turning.
- ▲ Do not use safety chain for towing.

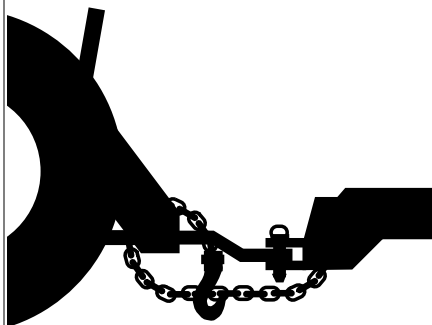

Practice Safe Maintenance

- ▲ Understand procedure before doing work. Use proper tools and equipment, refer to Operator's Manual for additional information.
- ▲ Work in a clean dry area.
- ▲ Lower the implement to the ground, put tractor in park, turn off engine, and remove key before performing maintenance.

- ▲ Allow implement to cool completely.
- ▲ Do not grease or oil implement while it is in operation.
- ▲ Inspect all parts. Make sure parts are in good condition & installed properly.
- ▲ Remove build-up of grease, oil or debris.
- ▲ Remove all tools and unused parts from implement before operation.



Important Safety Information

These are common practices that may or may not be applicable to the products described in this manual.

Prepare for Emergencies

- ▲ Be prepared if a fire starts.
- ▲ Keep a first aid kit and fire extinguisher handy.
- ▲ Keep emergency numbers for doctor, ambulance, hospital and fire department near phone.

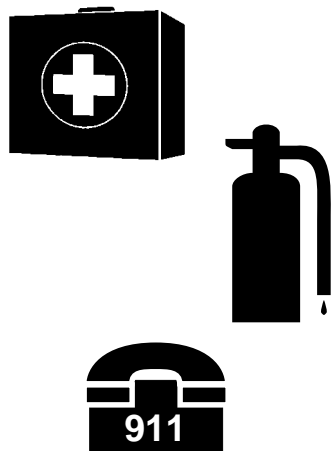

Wear Protective Equipment

- ▲ Protective clothing and equipment should be worn.
- ▲ Wear clothing and equipment appropriate for the job. Avoid loose fitting clothing.
- ▲ Prolonged exposure to loud noise can cause hearing impairment or hearing loss. Wear suitable hearing protection such as earmuffs or earplugs.
- ▲ Operating equipment safely requires the full attention of the operator. Avoid wearing radio headphones while operating machinery.



Avoid High Pressure Fluids Hazard

- ▲ Escaping fluid under pressure can penetrate the skin causing serious injury.
- ▲ Avoid the hazard by relieving pressure before disconnecting hydraulic lines or performing work on the system.
- ▲ Make sure all hydraulic fluid connections are tight and all hydraulic hoses and lines are in good condition before applying pressure to the system.
- ▲ Use a piece of paper or cardboard, NOT BODY PARTS, to check for suspected leaks.
- ▲ Wear protective gloves and safety glasses or goggles when working with hydraulic systems.
- ▲ If an accident occurs, see a doctor immediately. Any fluid injected into the skin must be treated within a few hours or gangrene may result.



Keep Riders Off Machinery

- ▲ Riders obstruct the operator's view, they could be struck by foreign objects or thrown from the machine.
- ▲ Never allow children to operate equipment.

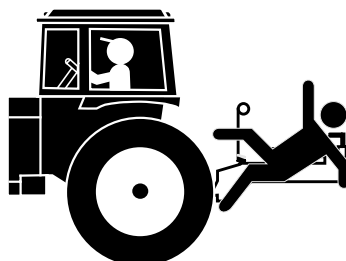

Important Safety Information

Safety Labels

Your Cutter comes equipped with all safety labels in place. They were designed to help you safely operate your implement.

1. Read and follow label directions.
2. Keep all safety labels clean and legible.
3. Replace all damaged or missing labels.
4. Some new equipment installed during repair require safety labels to be affixed to the replaced component as specified by Land Pride. When ordering new components make sure

- the correct safety labels are included in the request. To order new labels go to your Land Pride dealer.*
5. Refer to this section for proper label placement. To install new labels:
 - a. Clean the area the label is to be placed.
 - b. Spray soapy water on the surface where the label is to be placed.
 - c. Peel backing from label. Press firmly onto the surface.
 - d. Squeeze out air bubbles with the edge of a credit card.

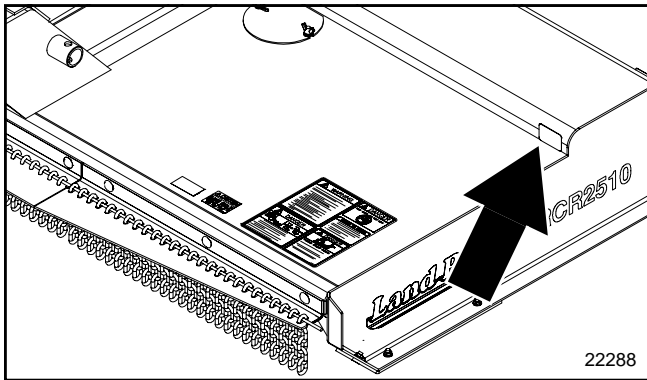

838-062C
Amber Reflector

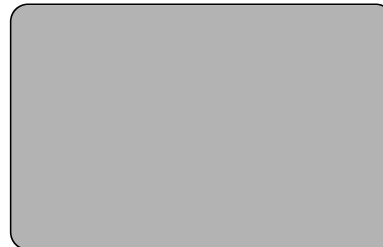
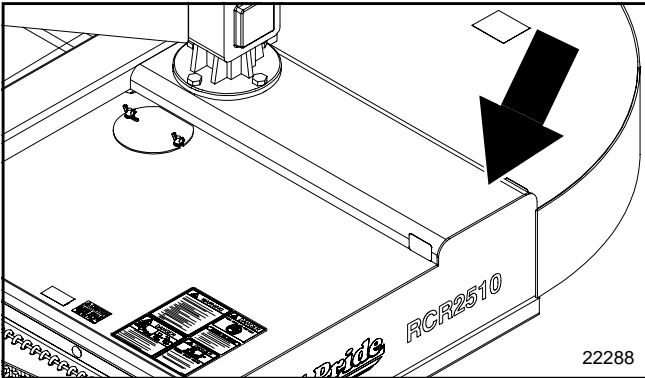

818-335C
Red Reflector

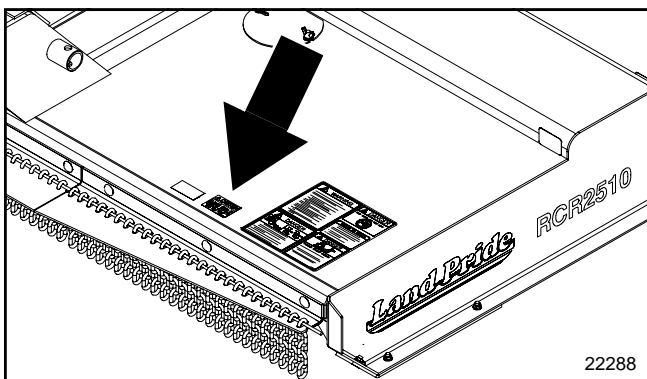

818-130C (Shown)
Caution 540 RPM

818-240C
Caution 1000 RPM

Important Safety Information

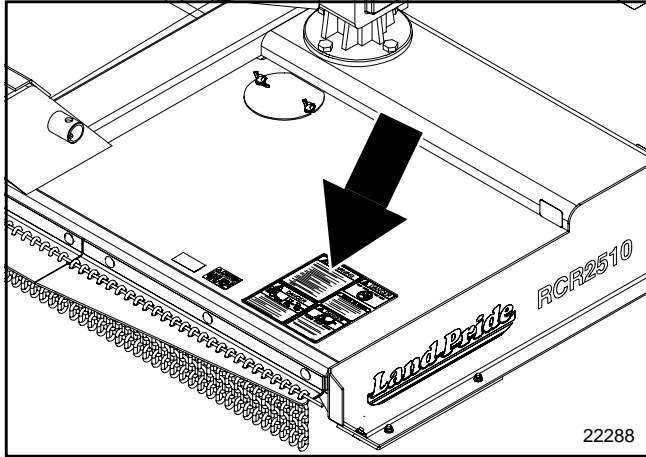

<p>! WARNING</p> <p>To prevent serious injury or death:</p> <ul style="list-style-type: none"> Read and understand Operator's Manual before using. Never attempt to Do not permit others on the tractor or implement carry children on tractor seat. Do not allow children to operate mower. Operate only with guards installed and in good condition. Operate only with tractor equipped with ROPS and seatbelts. Always remain clear seats from mowing area. Do not operate in the raised position. Stop engine, set brake and exit for all moving parts to stop before dismounting. Equip tractor properly before mowing beneath limb. Transport with clean reflectors, 30V and working lights as required by Federal, state, and local laws. <p>Do not use ladders, step stools or similar that sit on parts that the tractor has no holdup or support.</p>	<p>! DANGER</p> <p>KEEP HANDS AND FEET AWAY</p>
<p>! DANGER</p> <p>ROTATING BLADES - KEEP AWAY</p> <p>To prevent serious injury or death when the engine is running and the blades are rotating:</p> <ul style="list-style-type: none"> Never allow riders, especially children, on tractor or mower. Do not operate with bystanders in mowing area. Do not operate with deflectors/guards removed. Do not place hands or feet under seat. 	<p>! NOTICE TO OWNER</p> <p>An OWNER'S MANUAL was attached to the implement when you received it. If it was not attached to the line of purchase, please contact your selling dealer of stock handling for help.</p> <ol style="list-style-type: none"> Read and understand Owner's Manual before you begin. Pay attention to the safety messages.
<p>! DANGER</p> <p>THROWN OBJECT HAZARD</p> <p>To prevent serious injury or death:</p> <ul style="list-style-type: none"> Do not operate unless all guards are installed and in good condition. Stop blade rotation if by unobstructed cone within several hundred feet. 	

818-830C
Safety Combo

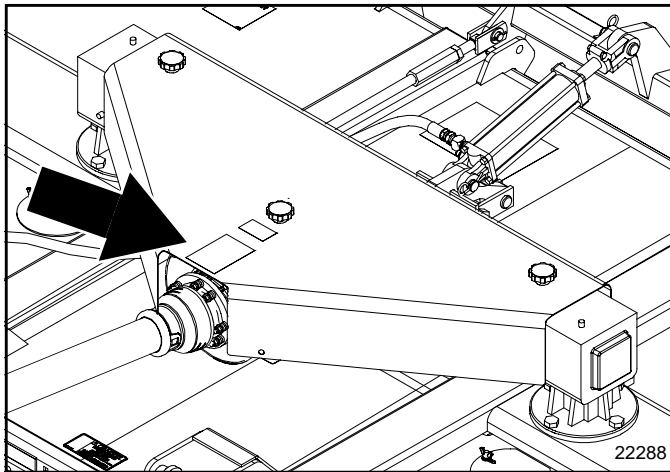

! DANGER

ROTATING DRIVELINE CONTACT CAN CAUSE DEATH
KEEP AWAY!
DO NOT OPERATE WITHOUT -

- All driveline guards, tractor and equipment shields in place
- Drivelines securely attached at both ends.
- Driveline guards that turn freely on Driveline

818-552C

818-552C
Danger PTO Driveline

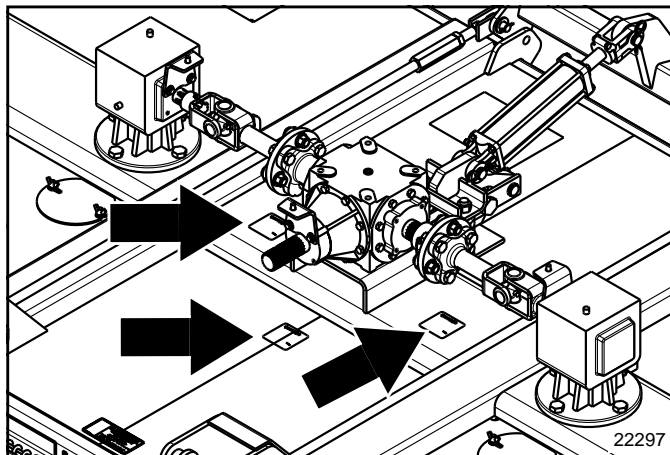

! DANGER

GUARD MISSING

When this is visible
DO NOT OPERATE

ENTANGLEMENT HAZARD
can cause Serious Injury or Death

Si no entiende inglés, se prefiere que busque a alguien que interprete las instrucciones para usted.

PHDC 6

818-543C
Danger Guard Missing

Important Safety Information

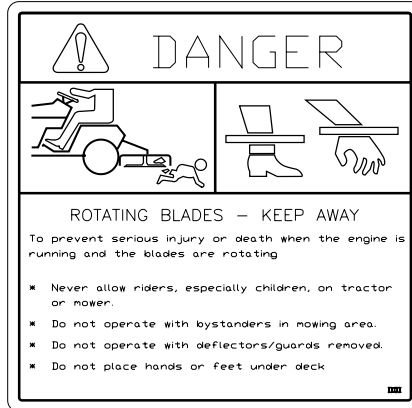
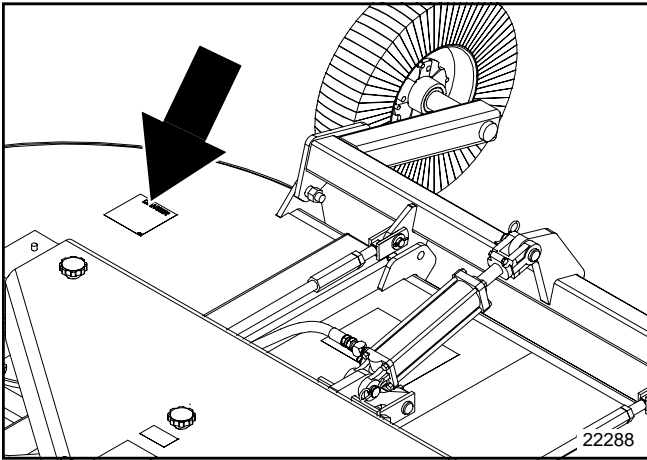

818-564C
Chain Shield

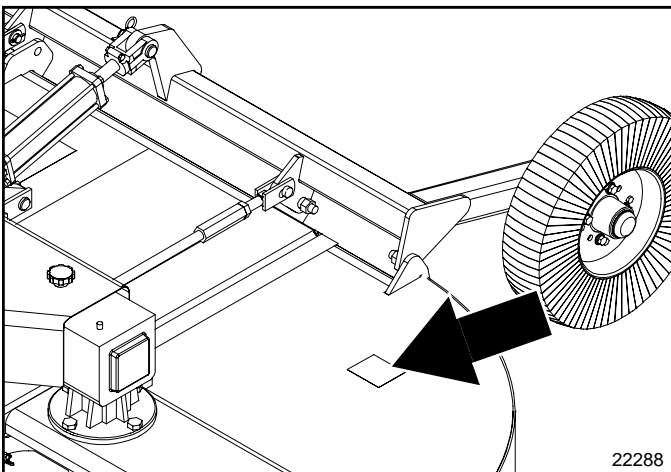

818-556C
Danger Thrown Object

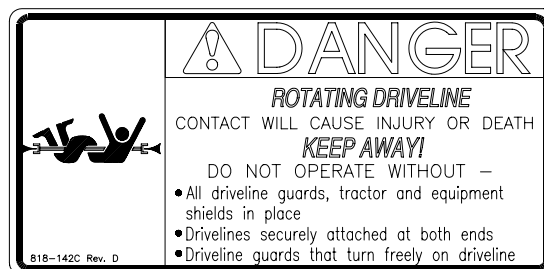
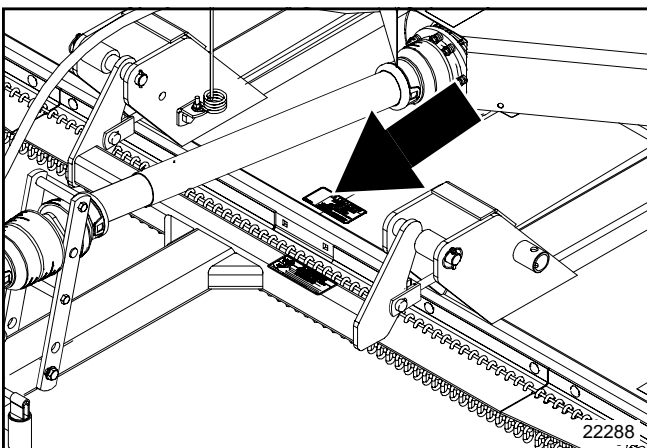

818-142C
Rotating Driveline

Important Safety Information

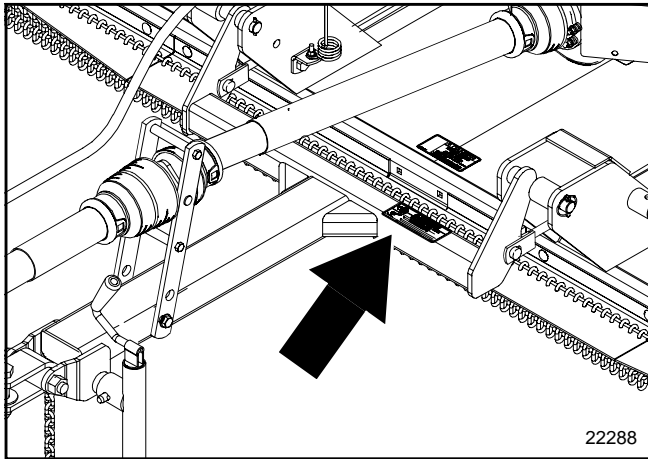

	<h1>WARNING</h1>
	<p>HIGH PRESSURE FLUID HAZARD</p> <p>To prevent serious injury or death:</p> <ul style="list-style-type: none"> • Relieve pressure on system before repairing or adjusting or disconnecting. • Wear proper hand and eye protection when searching for leaks. Use wood or cardboard instead of hands. • Keep all components in good repair. <p style="text-align: right;"><small>838-094C</small></p>

838-094C

Warning: High Pressure

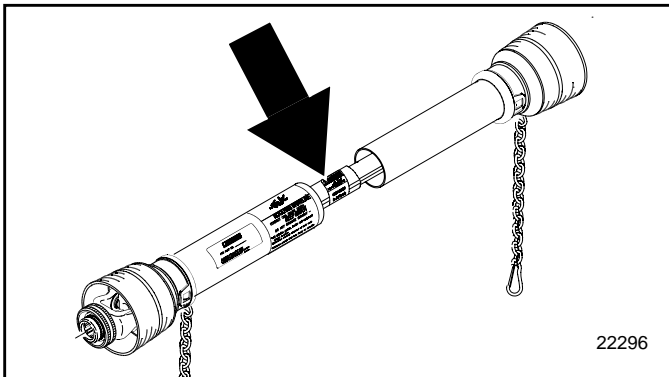

<p>⚠ DANGER</p>
<p>GUARD MISSING DO NOT OPERATE</p>
<p>⚠ DANGER</p>
<p>GUARD MISSING DO NOT OPERATE</p>
<p>⚠ DANGER</p>

818-540C

Danger Guard Missing
Do Not Operate

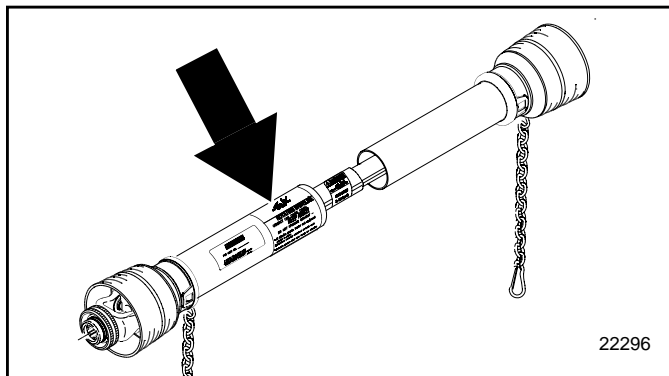

<p>⚠ DANGER</p>
<p>ROTATING DRIVELINE CONTACT CAN CAUSE DEATH KEEP AWAY! DO NOT OPERATE WITHOUT -</p> <ul style="list-style-type: none"> • All driveline guards, tractor and equipment shields in place • Drivelines securely attached at both ends. • Driveline guards that turn freely on Driveline <p style="text-align: right;"><small>818-552C</small></p>

818-552C

Rotating Driveline
Hazard Keep Away

Introduction

Land Pride welcomes you to the growing family of new product owners.

This Cutter has been designed with care and built by skilled workers using quality materials. Proper assembly, maintenance, and safe operating practices will help you get years of satisfactory use from the machine.

Application

The standard utility duty RCR2596, RCR2510 and RCRM2510 Series Rotary Cutters are designed and built by Land Pride to provide excellent cutting performance on gently sloping or slightly contoured right-of ways, pastures, set-aside-acres, and row crop fields. Their eight and ten foot cutting widths, 2" to 12" cutting height and ability to cut weeds and brush up to 1" diameter make them well suited for these applications.

The RCR2596 and RCR2510 cutters operate at a PTO speed of 540 rpm and the RCRM2510 cutter operates at 1000 rpm. A category four equal angle driveline is available on all three models and a category four constant velocity driveline is available on only the RCR2510 & RCRM2510 models.

Pull-type and three-point type hitches are available. The RCR2596 is designed for a category I or II three-point hitch and the RCR2510 and RCRM2510 are designed for a category II or III three-point hitch. All three-point hitches are Quick-Hitch adaptable. The RCR2596 three-point hitch requires a 45-110 hp tractor and the Pull-type hitch requires a 30-110 hp tractor. The RCR2510 and RCRM2510 three-point hitch requires a 50-110 hp tractor and 35-110 hp for Pull-type.

Stump jumpers, main driveline slip-clutches, and outboard flex couplers are also offered for driveline and gearbox protection. Safety shields around the cutter are offered in either chain or rubber.

See "Features and Benefits" section and "Product Specifications" for more information and performance enhancing options.

Using This Manual

- This Operator's Manual is designed to help familiarize you with safety, assembly, operation, adjustments, troubleshooting, and maintenance. Read this manual and follow the recommendations to help ensure safe and efficient operation.
- The information contained within this manual was current at the time of printing. Some parts may change slightly to assure you of the best performance.
- To order a new Operator's or Parts Manual contact your authorized dealer. Manuals can also be downloaded, free-of-charge from our website at www.landpride.com or printed from the Land Pride Service & Support Center by your dealer.

Terminology

"Right" or "Left" as used in this manual is determined by facing the direction the machine will operate while in use unless otherwise stated.

Definitions

NOTE: A special point of information that the operator must be aware of before continuing.

IMPORTANT: A special point of information related to its preceding topic. Land Pride's intention is that this information should be read and noted before continuing.

Owner Assistance

The Warranty Registration card should be filled out by the dealer at the time of purchase. This information is necessary to provide you with quality customer service.

If customer service or repair parts are required contact a Land Pride dealer. A dealer has trained personnel, repair parts and equipment needed to service the Cutter.

The parts on your Cutter have been specially designed and should only be replaced with genuine Land Pride parts. Therefore, should your Cutter require replacement parts go to your Land Pride Dealer.

Serial Number Plate

Refer to Figure 1:

For prompt service always use the serial number and model number when ordering parts from your Land Pride dealer. Be sure to include your serial and model numbers in correspondence also. Refer to Figure 1 for the location of your serial number plate.

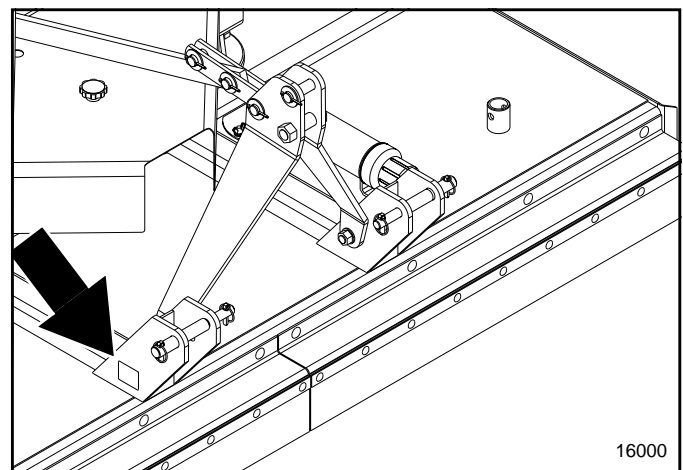

Serial Number Plate Location
Figure 1

Introduction

Further Assistance

Your dealer wants you to be satisfied with your new Cutter. If for any reason you do not understand any part of this manual or are not satisfied with the service received, the following actions are suggested:

1. Discuss the matter with your dealership service manager making sure he is aware of any problems you may have and that he has had the opportunity to assist you.
2. If you are still not satisfied, seek out the owner or general manager of the dealership, explain the problem and request assistance.
3. For further assistance write to:

Land Pride
Service Department
P.O. Box 5060
Salina, KS 67402-5060

Section 1: Assembly and Set-Up

Tractor Requirements

Weight & Horsepower

Tractor horsepower and weight must be capable of controlling the cutter under all operating conditions. Tractors outside the horsepower range must not be used.

- RCR2596 cutters
 - Three-point 45-110 HP
 - Pull-type 30-110 HP
- RCR2510 & RCRM2510 cutters
 - Three-point 50-110 HP
 - Pull-type 35-110 HP

NOTE: Ballast may need to be added to your tractor to maintain steering control. Refer to your tractor's operator manual to determine if one needs additional ballast.

PTO Type & Speed

Tractor's rear power take-off (PTO) speed and spline type must be capable of matching the cutter's PTO type and speed.

- RCR2596 and RCR2510 cutters
 - 540 RPM 1 3/8"-6 spline rear power take-off
- RCRM2510 cutters
 - 1000 RPM 1 3/8"-21 spline rear power take-off

Pull-Type Hitch

Refer to Figure 1-1

Distances between center of drawbar hitch pin hole to end of tractor PTO shaft ("A" dimension) and from top of drawbar hitch to center of PTO shaft ("B" dimension) must be maintained when using the Pull-type hitches.

- "A" = 14" for 540 rpm
- "A" = 16" for 1000 rpm
- "B" = 8" for 540 and 1000 rpm

IMPORTANT: PTO damage may occur if distances "A" and "B" are not properly maintained.

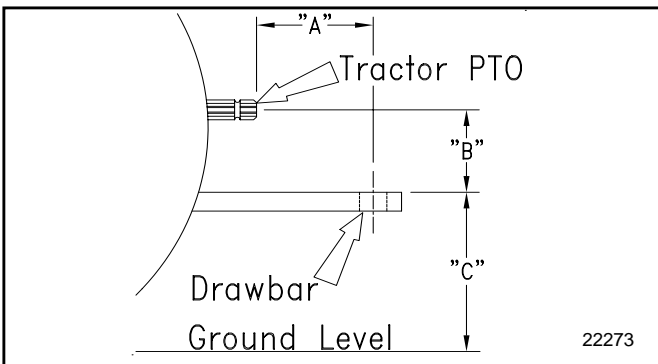

PTO to Drawbar Distances
Figure 1-1

3-Point Hitch

The lower 3-Point arms of the 3-Point hitch must be stabilized to prevent side-to-side movement. Most tractors have sway blocks or adjustable chains for this purpose. Category of hitch is dependent upon the series of cutter being used.

- RCR2596 (Category I or II hitch)
- RCR2510 & RCRM2510 (Category II or III hitch)

Dealer Preparations

Read and understand the operator's manual for your cutter. An understanding of how it works will aid in the assembly and setup of your cutter.

This Rotary Cutter has been partially assembled at the factory. However, some assembly will be necessary to attach the hitch, driveline and guards to the cutter.

It is best to go through the **Pre-Assembly Checklist** before assembling the cutter. Speed up your assembly task and make the job safer by having all the needed parts and equipment readily at hand.

Pre-Assembly Checklist

Check	Reference
<input type="checkbox"/> Fasteners and pins that were shipped with the cutter. NOTE: All hardware from the factory has been installed in the location where it will be used. If a part or fastener is temporarily removed for assembly reasons, remember where it goes. Keep the parts separated.	Operator's Manual
<input type="checkbox"/> Be sure the parts get used in the correct location. By double checking while you assemble, you will lessen the chance of using a bolt incorrectly that may be needed later.	Operator's Manual
<input type="checkbox"/> All grease fittings are in place and lubricated.	Section 5 Page 32
<input type="checkbox"/> Safety labels are correctly located and legible. Replace if damaged.	Safety Information pg. 1
<input type="checkbox"/> Inflate tires to specified PSI air pressure. Tighten wheel bolts to specified torque.	Section 8 Page 38
<input type="checkbox"/> Red and amber reflectors are correctly located and visible when the cutter is in the transport position.	Safety Information Page 1
<input type="checkbox"/> Have a minimum of 2 people at hand while assembling the cutter.	Operator's Manual
<input type="checkbox"/> Have a fork lift or loader along with chains and safety stands that are sized for the job ready for the assembly task.	Operator's Manual

Section 1: Assembly and Set-Up

Gearbox Vent Plug

Refer to Figure 1-2

Gearbox vent plugs are shipped loose and packaged with the Operator's Manual. Remove existing splitter gearbox pipe plug and replace with 3/8" vent plug. Remove wing box pipe plugs and replace with 1/2" vent plugs.

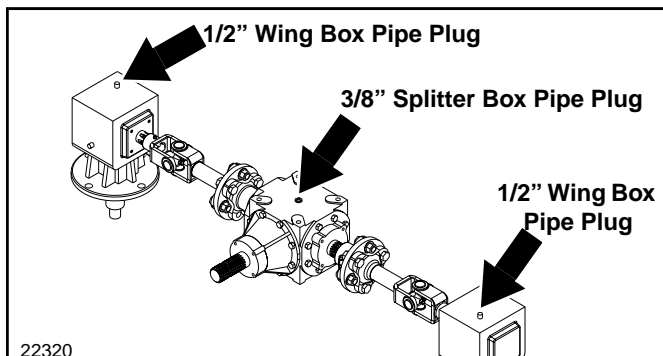

Figure 1-2

Lift-Type Cutter

Hitch Assembly

NOTE: Do not tighten hardware until assembly is complete. Refer to "Torque Values Chart for Common Bolt Sizes" on page 38.

Refer to Figure 1-3:

1. Assemble the A-Frame hitch (#11) to the lower bolt holes of the front inside hitch ears as shown. Insert the 5/8" long bushings (#14) into the bottom holes of

the A-Frame hitch. Secure the A-Frame hitch with the 3/4" bolts (#15), 3/4" flat washer (#13) and 3/4" lock nut (#12).

2. Place the 2" long bushing (#17) between the A-Frame hitch as shown and insert 1" bolt (#9) through the hole in the hitch and bushing. Secure with the 1" lock nut (#10).
3. Assemble the two short braces (#8) that are on the rear brace (#1) between the back holes of the A-Frame (#11) using the clevis pin (#18) provided and secure with the flat washer (#21) and cotter pin (#19).
4. Assemble the two longer straight braces (#5) to the front hole of the lug that is welded behind the gearbox mount. Secure with the 1" bolt (#6) and lock nut (#7).
5. Assemble the formed rear braces (#2) to the inside of the inner most lugs at the rear of the cutter. Secure with the 3/4" bolt (#3) and lock nut (#4).
6. Install the other clevis pin (#18), flat washer (#21) and cotter pin (#19) into the top front hole of the A-Frame.

Driveline Installation

1. Attach the slip-clutch end of the driveline (#16) to the gearbox input shaft securely. Make certain that the slip-clutch is fully onto the input shaft splines. Tighten the conical dog pin on back side of slip-clutch to 45-50 ft-lb torque.
2. Secure chain #20 to hole in driveline guard. Driveline guard not shown.

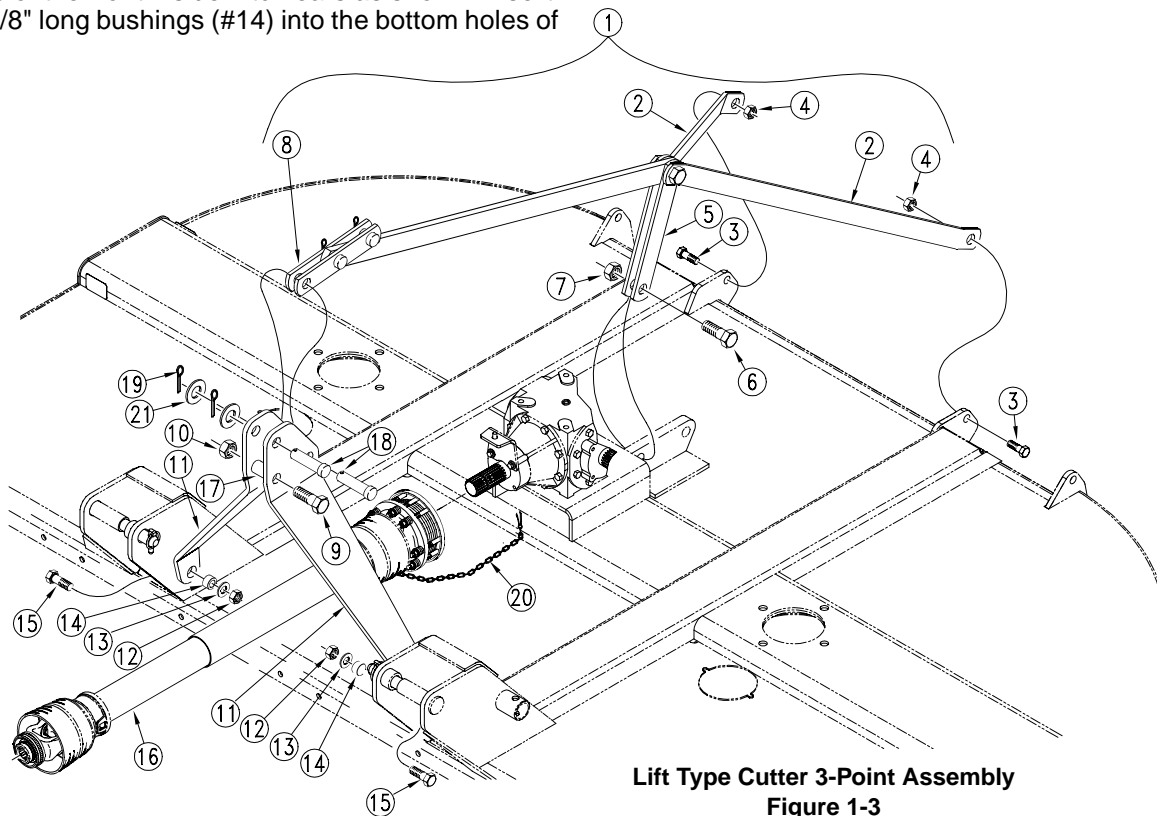

Lift Type Cutter 3-Point Assembly
Figure 1-3

22289

Section 1: Assembly and Set-Up

Pull-Type Cutter

Hitch Assembly

NOTE: Do not tighten hardware until assembly is complete. Refer to “Torque Values Chart for Common Bolt Sizes” on page 38.

Refer to Figure 1-4 for RCR2596 hitch assembly and Figure 1-5 for RCR2510 hitch assembly:

1. Assemble tongue (#1) to the deck using hitch pins (#2), spacer tubes (#3) and linch pins (#4).

2. Attach level rod assemblies (#8) to tongue (#1) using clevis pins (#5), flat washers (#6) and cotter pins (#7). Make sure level rod adjusting nuts are threaded the same distance on both rods. This will ensure a level unit.
3. Remove hydraulic hose holder (#9) from the hitch and install to the cutter deck with 3/4" x 1 1/2" GR5 hex head cap screw (#12) and 3/4" hex locknut (#13) as shown. Tighten mounting bracket hardware as needed to secure hose holder in place.
4. Route hydraulic hose through the hose holder loop.
5. Remove parking jack (#10) from its storage position on the deck and attach to the tongue (#1). Secure with attached pin (#11). Adjust jack to desired height.

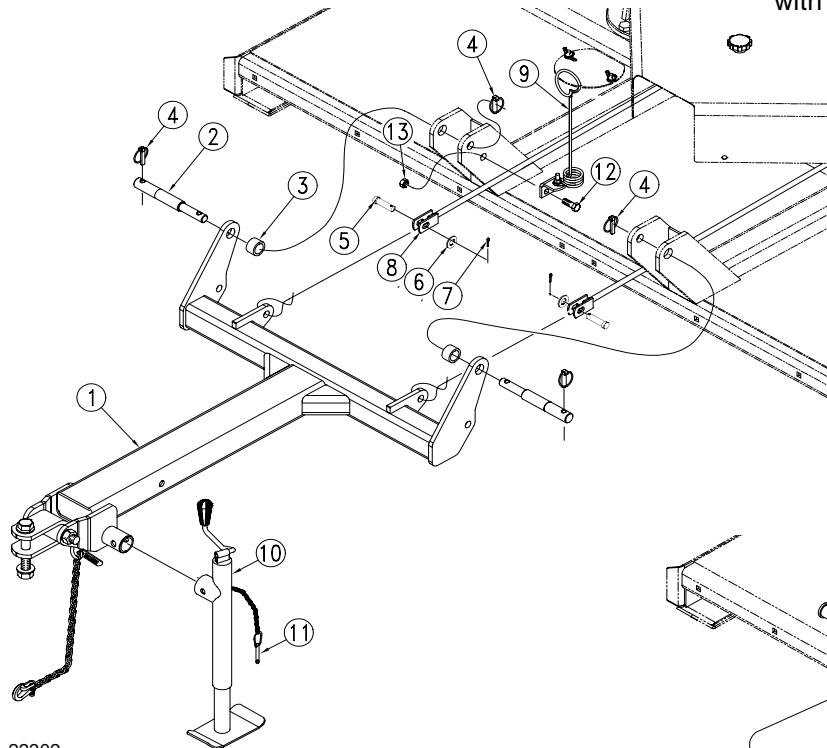

22302

RCR2596 Hitch Assembly
Figure 1-4

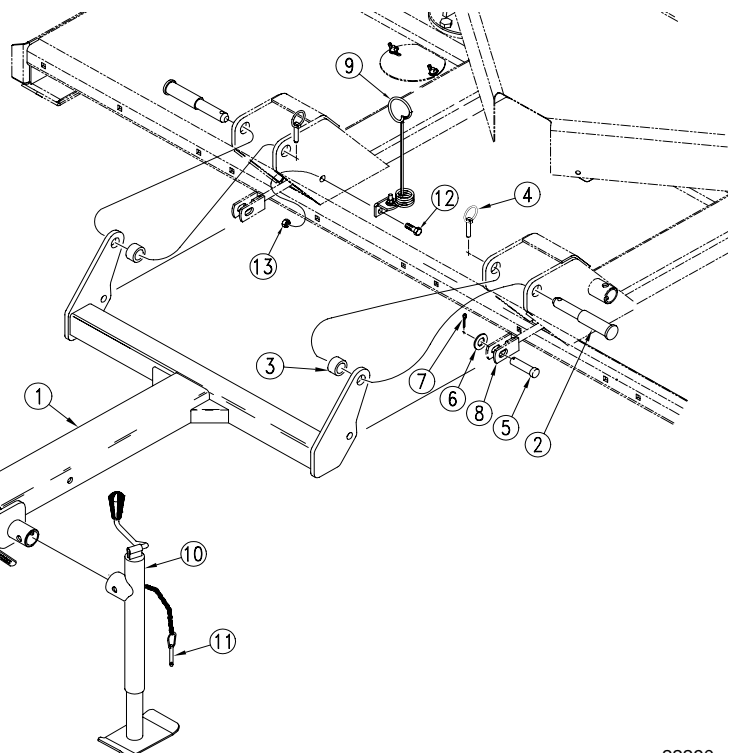

22290

RCR2510 Hitch Assembly
Figure 1-5

Section 1: Assembly and Set-Up

Equal Angle Driveline Installation

Refer to Figure 1-6:

Equal angle drivelines can be installed on RCR2596, RCR2510 and RCRM2510. Maximum turning angle is limited to 35 degrees.

1. Remove gearbox cover (cover not shown).
2. Securely attach the slip-clutch end of the driveline jackshaft (#2) to the gearbox input shaft (#1). Make certain the slip-clutch is fully on the gearbox input shaft. Tighten the conical dog pin on the connection to 45-50 ft-lbs. of torque.

IMPORTANT: Make sure the bearing (#3) in bearing support has its locking collar facing the cutter gearbox (#1).

3. Insert driveline jackshaft (#2) through the bearing support assembly (#3). Pull the bearing support assembly fully against the jackshaft to extend the jackshaft splines through the bearing and out the other side as far as possible.

4. Install main driveline (#4) to jackshaft (#2) by pulling on the collar and pushing the yoke forward to engage the groove on the jackshaft splined stub until the collar has locked in place. Make certain the locking collar has engaged by pulling on the main driveline.
5. Tighten the set screw in the bearing locking collar (#3).
6. Replace gearbox cover.
7. Secure chain (#5) on the main driveline (#4) to the bearing support assembly (#3). Secure chain (#6) on the jackshaft driveline (#2) to the hole on the left side of the gearbox cover (cover not shown). Securing chains will restrict driveline outer shields from rotating.

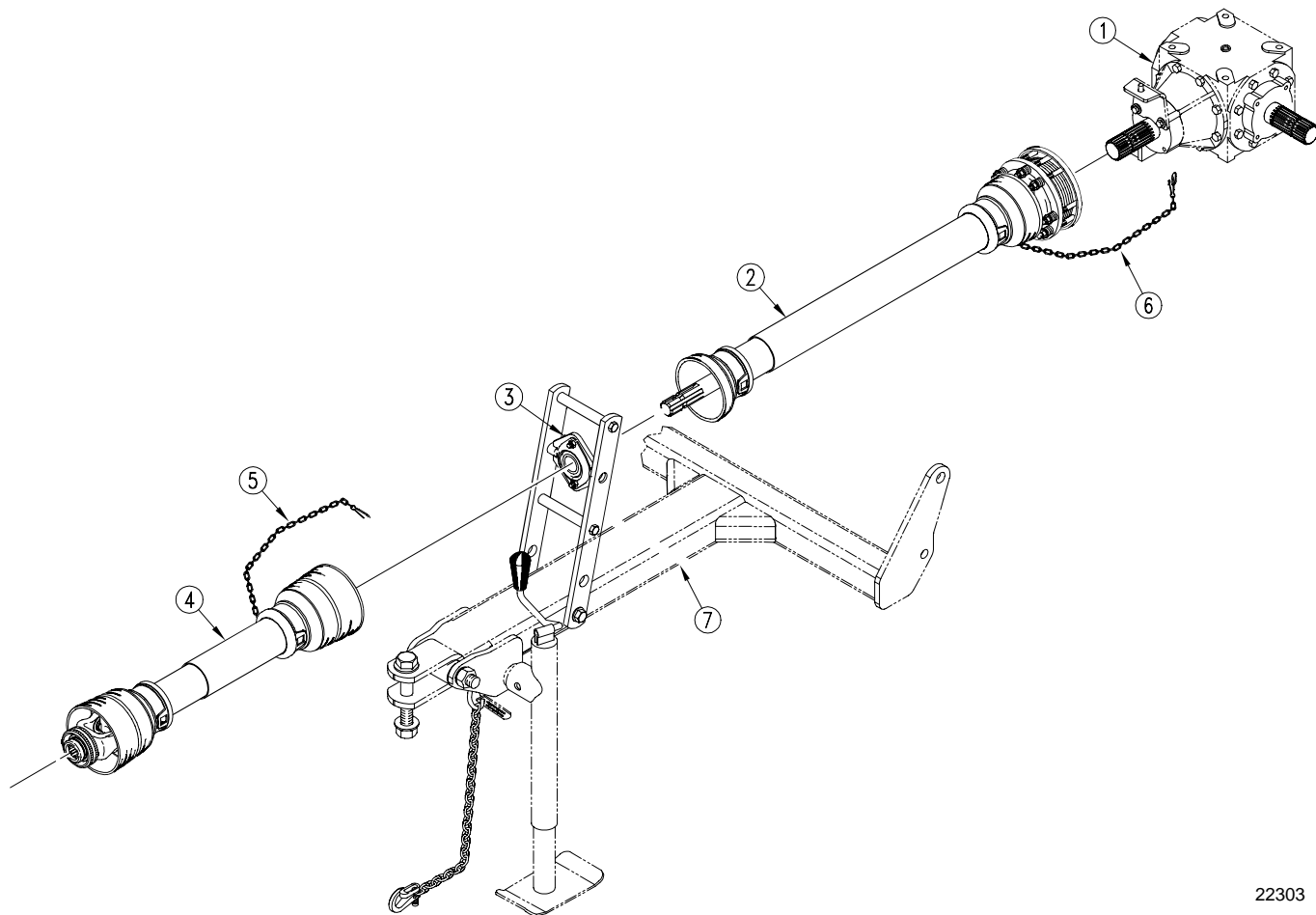

22303

RCR2596, RCR2510 & RCRM2510
Equal Angle Driveline Assembly
Figure 1-6

Section 1: Assembly and Set-Up

Constant Velocity Driveline Installation

NOTE: Do not tighten hardware until assembly is complete. Refer to “**Torque Values Chart for Common Bolt Sizes**” on page 38.

Refer to Figure 1-7:

Constant velocity driveline can be installed on RCR2510 and RCRM2510 cutters only. Maximum turning angle is limited to 80 degrees.

1. Securely attach slip-clutch end of jackshaft driveline (#1) to gearbox input shaft (#8). Make certain the slip-clutch is fully on the gearbox input shaft. Tighten the conical dog pin on the connection to 45-50 ft-lb torque.
2. Insert jackshaft driveline (#1) into pillow block bearing (#9). Secure bearing support (#2) with 1/2"-13 x 3 1/2" long bolts (#3) and 1/2" flange nuts (#4).
3. Install main driveline (#5) to jackshaft driveline (#1) by attaching the (red) slide collar on the jackshaft. Twist the quick disconnect on the yoke and push it forward to engage the groove on the jackshaft splined stub.
4. Secure chain (#7) to the tongue (#10) to restrict driveline outer shield from rotating. Secure jackshaft driveline chain (#6) to the hole in the left side of the gearbox cover (cover not shown). Securing chains will restrict driveline outer shields from rotating.
5. Tighten nuts (#4) to proper torque.

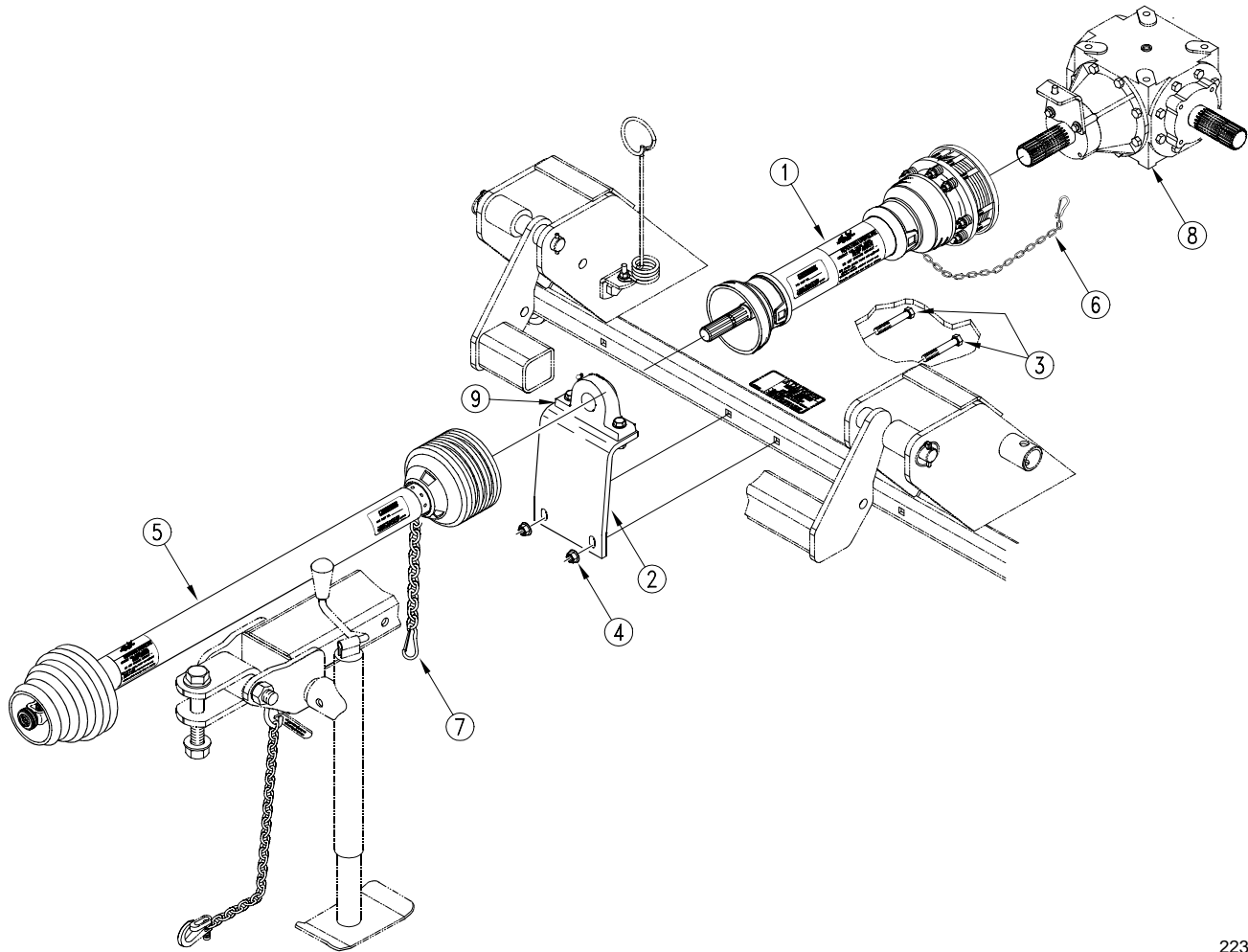

22304

**RCR2510 & RCRM2510
Constant Velocity Driveline Assembly
Figure 1-7**

Section 1: Assembly and Set-Up

Chain Safety Shields (Optional)

! DANGER!

Rotary Cutters have the ability to discharge objects at high speeds; therefore, the use of front and rear safety shields is strongly recommended when cutting along highways or in an area where people may be present.

NOTE: Do not tighten hardware until assemblies are complete. Refer to "Torque Values Chart for Common Bolt Sizes" on page 38.

Front Chain Shields (RCR2596)

Refer to Figure 1-8

Install each front chain shield (#1) with 1/2"-13 x 2 3/4" long carriage bolts (#2) and flange nuts (#3) as shown.

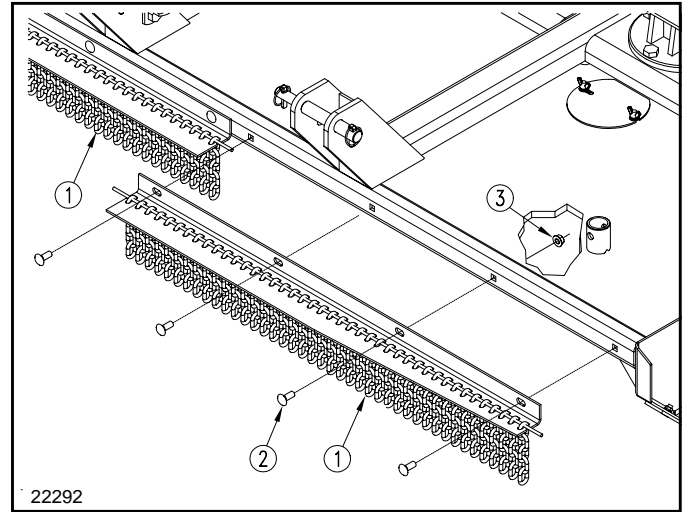

RCR2596 Front Chain Shield
Figure 1-8

Front Chain Shields (RCR(M)2510)

Refer to Figure 1-9

Install front chain shields (#1) & (#2) with 1/2" -13 x 3 1/2" long carriage bolts (#3) and flange nuts (#4) as shown.

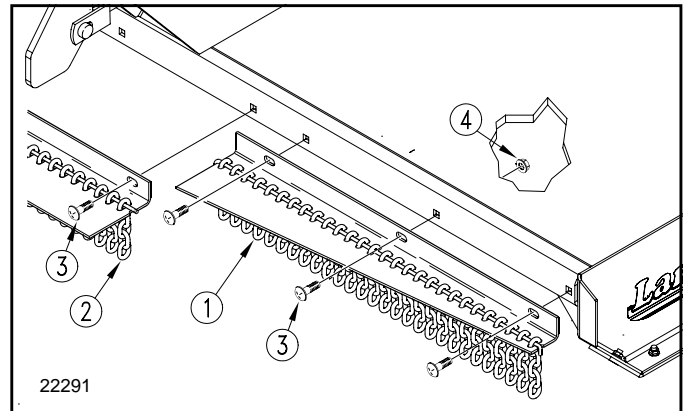

RCR2510 & RCRM2510 Front Chain Shield
Figure 1-9

Rear Chain Shield

Refer to Figure 1-10

Install rear chain shield (#1) with 1/2" -13 x 1 1/2" long carriage bolts (#2) and 1/2" flange nuts (#3) as shown.

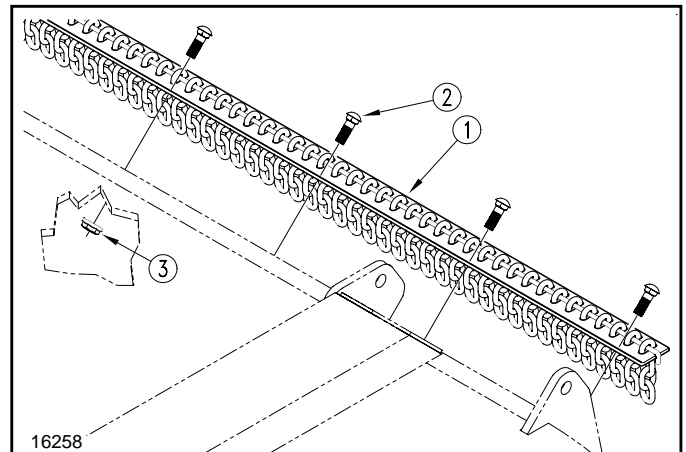

Rear Chain Shield
Figure 1-10

Section 1: Assembly and Set-Up

Rubber Safety Shields (Optional)



Rotary Cutters have the ability to discharge objects at high speeds; therefore, the use of front and rear safety shields is strongly recommended when cutting along highways or in an area where people may be present.

NOTE: Do not tighten hardware until assemblies are complete. Refer to “Torque Values Chart for Common Bolt Sizes” on page 38.

Front Rubber Shields (RCR2596)

Refer to Figure 1-11

Install front rubber shields (#1) with 1/2” -13 x 2 3/4” long carriage bolts (#2) and flange nuts (#3) as shown.

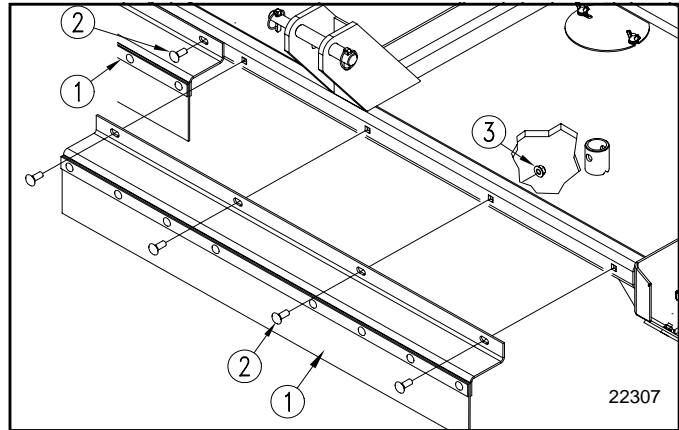

RCR2596 Front Rubber Shields
Figure 1-11

Front Rubber Shields (RCR(M)2510)

Refer to Figure 1-12

Install front rubber shields (#1) & (#2) with 1/2” -13 x 3 1/2” long carriage bolts (#3) and flange nuts (#4) as shown.

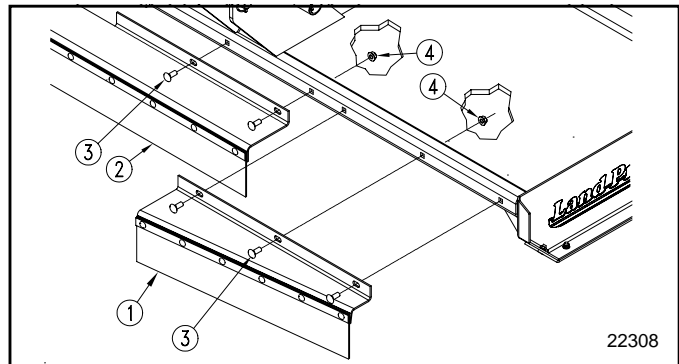

RCR2510 & RCRM2510 Front Rubber Shields
Figure 1-12

Rear Rubber Shield

Refer to Figure 1-13

Install rear rubber shield (#1) and rear shield strap (#2) with 1/2” -13 x 1 1/2” long carriage bolts (#3) and 1/2” flange nuts (#4) as shown.

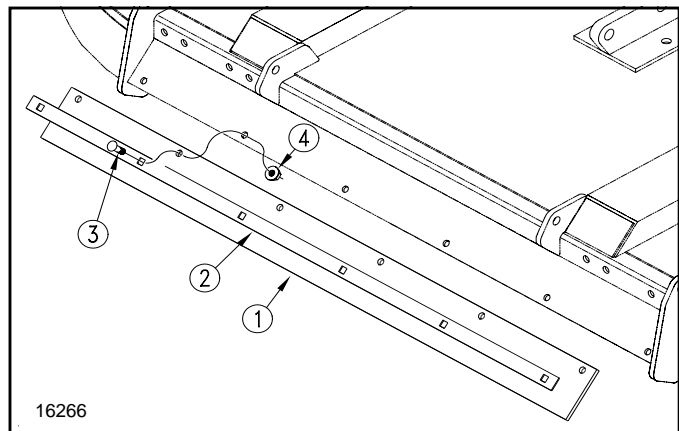

Rear Rubber Shield
Figure 1-13

Section 1: Assembly and Set-Up

3-Point Tractor Hook-Up

Refer to Figure 1-14:



DANGER!

Tractor hook-up can be hazardous to you or your helper. Do not allow anyone to stand between the cutter and tractor during hook-up operations. Do not operate hydraulic 3-point lift controls while someone is directly behind the tractor.



CAUTION!

Always engage parking brake, shut off tractor and remove key before dismounting from tractor.

1. Locate the cutter on a flat level surface.
2. Determine the hitch category of the tractor that will be used:
 - a. **Category I** tractors will have a lower hitch link hole diameter of 7/8". The top link hole diameter (cutter end) will be 3/4".
 - b. **Category II** tractors will have a lower hitch link hole diameter of 1 1/8". The top link hole diameter (cutter end) will be 1".
 - c. **Category III** tractors will have a lower hitch link hole diameter of 1 7/16". The top link hole diameter (cutter end) will be 1 5/16".
3. Remove lower linch pins (#3) and hitch pins (#1) from the deck. Remove upper cotter pin (#6), washer (#7) and hitch pin (#5) from the deck.

4. Slowly back the tractor up the cutter while using the tractor's 3-point hydraulic control to adjust the lower link arms up or down to match the tractor's lower arm pin holes to the cutter hitch pin holes. The lower lift arms of a Category 2 tractor will be positioned to the outside of the cutters lower hitch lugs on the RCR2596 & RCRM2596 cutters.
5. Re-insert hitch pins (#1) and secure with the linch pins (#3).
6. Connect the top center link (#4) to the upper pivot hitch using 1" clevis pin (#5), washer (#6) and cotter pin (#7). Bend cotter pin after inserting to prevent it from falling out.
7. The lift link rods on your tractor's 3-point hitch should be adjusted to allow for lateral float. Please consult you tractor's manual for adjusting instructions.

Driveline Hook-up

An additional driveline may be required if the Rotary Cutter is used on more than one tractor especially if a quick hitch is used.



CAUTION!

Do not use a PTO adaptor. A PTO adaptor will increase the strain on the tractor's PTO shaft and can damage the PTO shaft and mower driveline.



CAUTION!

Do not over speed PTO. The cutter can be damage when operated above its rated PTO RPM.

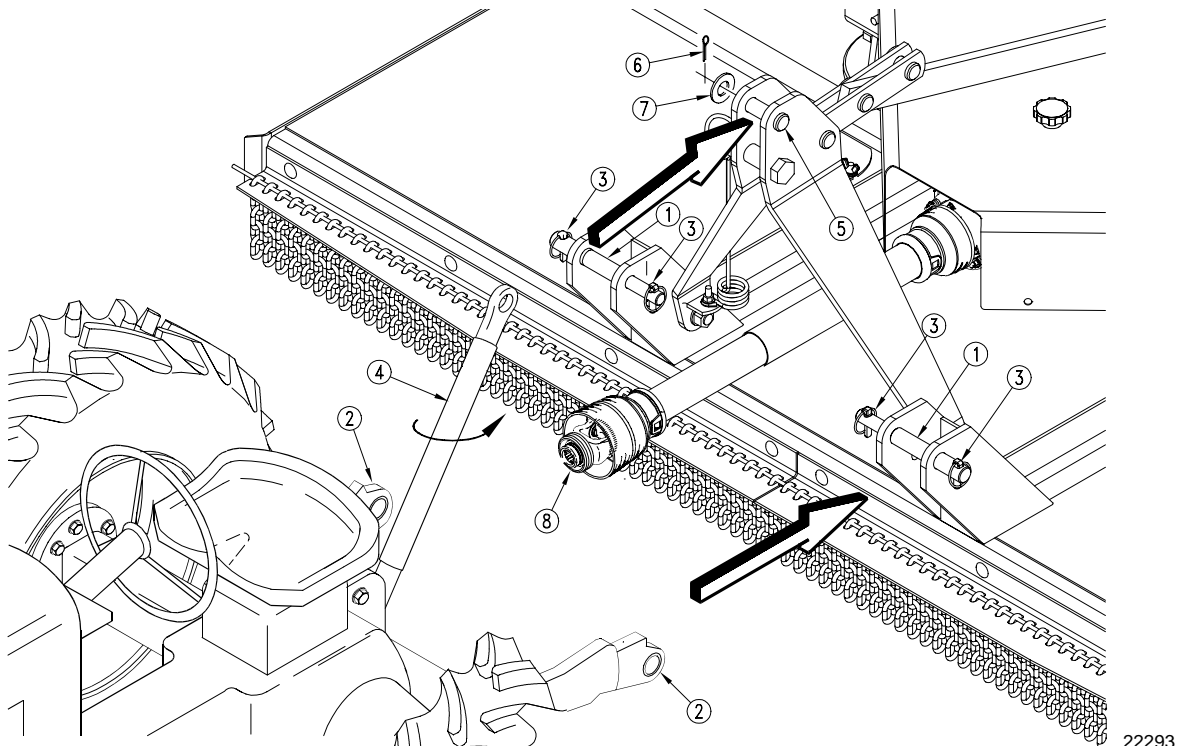

3-Point Lift Type Cutter Tractor Hook-Up
Figure 1-14

22293

Section 1: Assembly and Set-Up

WARNING!

Damaged drivelines can cause serious injury or death.

Either a tractor with 540 rpm or 1000 rpm PTO (Power Take-Off) speed is required. The RCR cutters are designed for a PTO speed of 540 rpm and the RCRM cutters are designed for 1000 rpm.

IMPORTANT: Do not attempt to operate a 540 RPM driveline cutter with a 1,000 RPM PTO tractor and do not operate a 1000 RPM driveline cutter with a 540 RPM PTO tractor. Many tractors provide both 540 and 1,000 RPM PTO speeds. Check your tractor's manual to determine its capabilities.

IMPORTANT: Avoid premature driveline breakdown. A driveline that is operating **must not exceed** an angle of 25 degrees up or down while operating 3-point lift. See Figure 1-15 below.

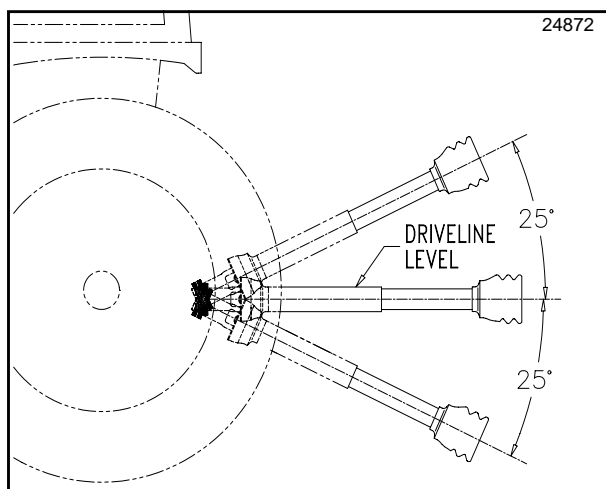

Maximum PTO Driveline Movement During Operation
Figure 1-15

Checking Driveline Minimum Length

IMPORTANT: Always check driveline minimum length during initial setup, when connecting to a different tractor and when alternating between using a quick hitch and a standard 3-point hitch. More than one driveline may be required to fit all applications.

IMPORTANT: It is necessary to align and level the tractor's PTO shaft with the gearbox shaft when checking driveline minimum length. Too long a driveline can damage tractor, gearbox and driveline.

Refer to Figure 1-14 on page 17:

1. Obtain the shortest distance possible between tractor PTO shaft and gearbox shaft by starting the tractor and slowly engaging 3-point lift to move the lower arms up or down until the gearbox shaft is

aligned and level with the tractor's PTO shaft. Securely block cutter deck in this position.

2. Place tractor gear selector in park, shut tractor engine off, set park brake and remove switch key.
3. Attach driveline to cutter and tractor as follows:
 - a. Slide inner yoke of driveline over the gearbox shaft and secure with locking collar.
 - b. Slide outer yoke of driveline over the tractor's PTO shaft and secure with locking collar.
 - c. Skip to step 5 if driveline fits between tractor and Rotary Cutter.

Refer to Figure 1-16:

4. The driveline will require shortening if it is too long to fit between the tractor and Rotary Cutter. Shorten driveline as follows:
 - a. Check to make sure cutter and tractor PTO shafts are level with each other and the deck is securely supported at this height with support blocks.
 - b. Pull driveline profiles apart into two sections as shown in Figure 1-16.

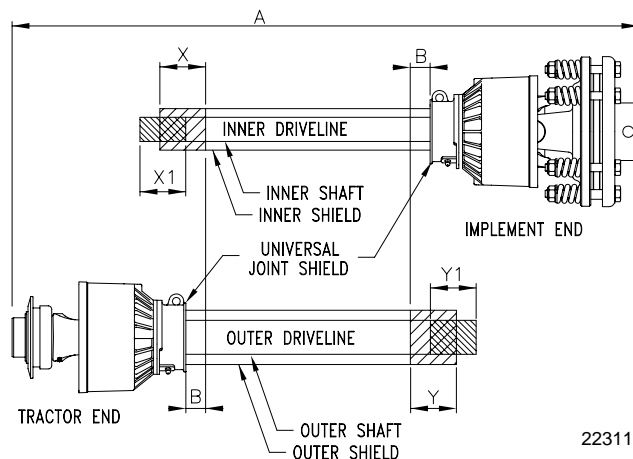

Driveline Shortening
Figure 1-16

- c. Attach outer driveline universal joint to tractor PTO shaft and inner driveline universal joint to gearbox shaft. Pull on each driveline section to be sure universal joints are secured.
- d. Hold driveline sections parallel to each other to determine if they are too long. The inner and outer shields on each section should end approximately 1" short of reaching the universal joint shield on the adjacent section (see "B" dimension). If they are too long, measure 1" ("B" dimension) back from the universal joint shield and make a mark at this location on the inner and outer shields.
- e. Cut off inner shield at mark ("X" dimension). Cut same amount off inner shaft ("X1" dimension). Repeat cut off procedure ("Y" & "Y1" dimensions) to cut outer driveline half.
- f. Remove all burrs and cuttings.

Section 1: Assembly and Set-Up

5. With driveline profiles pulled apart, apply multi-purpose grease to the inside of the outer profile and reassemble the two profiles.
6. Attach inner driveline yoke to the gearbox shaft and outer driveline yoke to the tractor PTO shaft.
7. The driveline should now be moved back and forth to insure that both ends are secured. Reattach any end that is loose.

IMPORTANT: Two small chains are supplied with the driveline. These chains must be attached to the outer and inner driveline yoke shields and to the cutter deck and tractor to keep the driveline shields from rotating.

8. Hook a safety chain in the hole on the outer driveline yoke shield and its opposite end to the tractor.
9. Hook the other safety chain in the hole on the inner driveline yoke shield and its opposite end to the cutter.
10. Start tractor and raise Rotary Cutter just enough to remove support blocks from under the cutter deck.
11. Slowly engage tractor's 3-point controls to lower the cutter. Check for sufficient drawbar clearance. Move drawbar ahead, aside or remove if required.

Section 1: Assembly and Set-Up

Pull-Type Tractor Hook-Up

Refer to Figure 1-17

! DANGER!

Crushing Hazard between tractor and implement. Do not allow anyone to stand between the tractor and implement while backing-up to an implement. Never operate the hydraulic 3-point lift controls while someone is directly behind the tractor.

Refer to Figure 1-17:

IMPORTANT: Jack attachment pin (#2) must be fully inserted and secured before working on or around a cutter that is not hooked to the tractor drawbar.

1. Make certain jack stand (#1) is properly attached to the cutter hitch and secured with attachment pin (#2).
2. Back tractor within close proximity of cutter clevis (#6).
3. Raise or lower jack (#1) to align clevis (#6) with tractor drawbar. Drawbar should fit between lower and upper plates of clevis.
4. Back tractor up to cutter hitch until holes in the drawbar and clevis (#6) are aligned.
5. Insert 1" flat washers (#5) above and below tractor drawbar.
6. Insert 1" -8 x 4 1/2" gr5 hex bolt (3) through top of clevis (#6), 1" washer (#5), drawbar, remaining 1" washers (#5) and out through bottom of clevis (#6). Secure hex bolt with locknut (#4). Tighten nut snugly to remove all play and then back nut one-quarter turn.

NOTE: May need to adjust the leveling rod nut couplers to obtain correct drawbar height.

7. Attach driveline yoke end (#8) to tractor PTO shaft. Secure with locking device. Pull on both end of the driveline to make sure it is secured to the tractor and gearbox shafts.
8. Attach hydraulic hose (#9) to tractor hydraulic outlet.
9. Fully retract the jack stand (#1), remove locking pin (#2) and store parking jack on the cutter deck with locking pin as shown.

Safety Chains

Refer to Figure 1-17:

When towing implements on the highway, use a safety chain (#7) with tensile strength equal to or greater than the gross weight of the implement to be towed by the tractor. This will control the implement in the event the hitch pin is lost.

Attaching safety chain (#7) to the tractor. Lock chain hook securely to the safety chain. Make a trial run by driving the tractor to the right and to the left for a short distance to check the safety chain adjustment. If necessary, re-adjust to eliminate a tight or loose chain.

Pull-Type Tractor Un-Hook

Refer to Figure 1-17

1. Park cutter on a level solid hard surface. Place tractor gear selector in park and set park brake.

NOTE: Always place jack stand on firm surface or place board under jack stand for support.

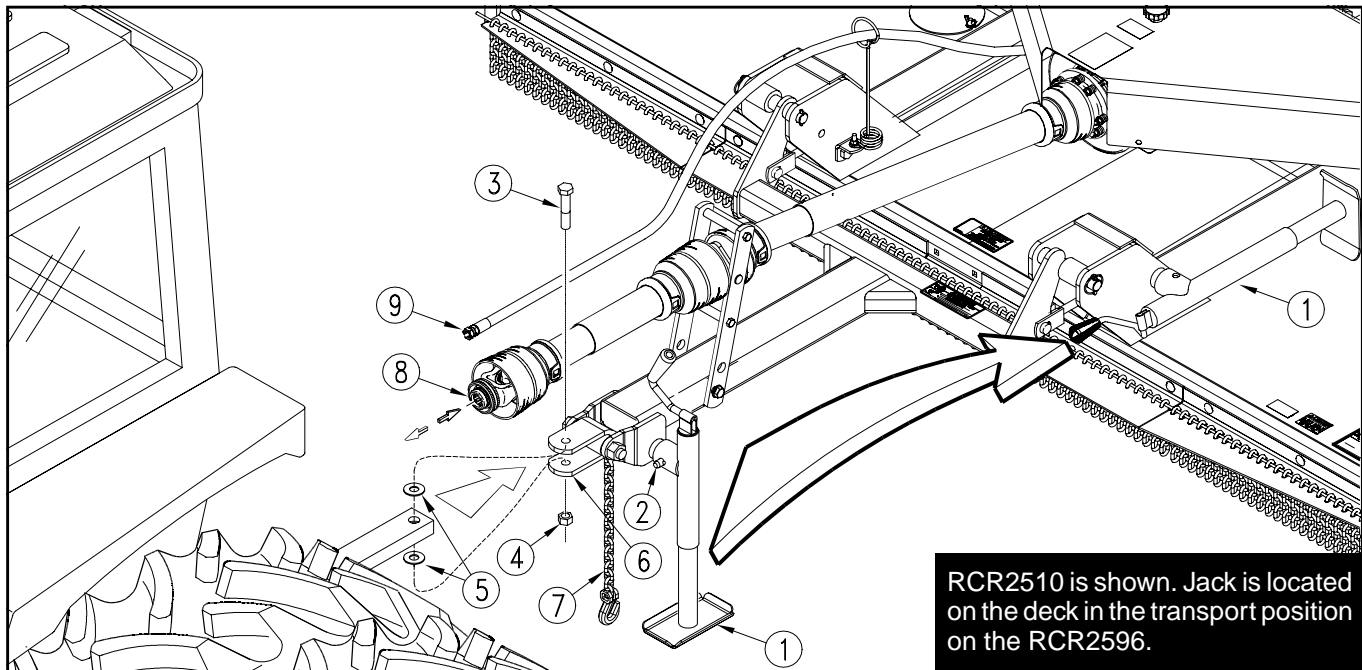

Pull-Type Tractor Hook-Up
Figure 1-17

Section 1: Assembly and Set-Up

2. Remove parking jack (#1) from cutter deck and secure to cutter tongue by fully inserting locking pin (#2) through the parking jack and mounting bracket as shown.
3. Add stroke control spacers to the cylinder rod to prevent the cylinder from retracting. See **"Pull-Type Cutter"** on page 23.
4. Use parking jack (#1) to raise and lower cutter tongue to the correct height to disconnect clevis hitch (#6) from the tractor drawbar.
5. Remove 1"-8 x 4 1/2" hex bolt (#3), flat washers (#5) and locknut (#4) from the clevis hitch (#6).
6. Disconnect hydraulic hose (#9) from tractor. Store hose end on cutter deck.

Check Chains, 3-Point Lift-Type Cutters

(Available through Land Pride parts department.)

Refer to Figure 1-18:

Check chains are used to control the cutting height and allow the mower to be lowered to the same preset cutting height effortlessly.

1. Install lower end of check chain (#1) to the inner hitch ear as shown in Figure 1-18, using the 3/4"-10 x 1 1/2 long bolts (#2), lock washers (#3) and nuts (#4). Tighten securely.
2. Install chain lugs (#5) on either side of the tractor top link mount using pin (not supplied).
3. Cutting height is then set by placing proper chain link in key slot (#5).

NOTE: For additional safety in transport, raise cutter as high as possible, and shorten check chains to prevent inadvertent falling in transport.

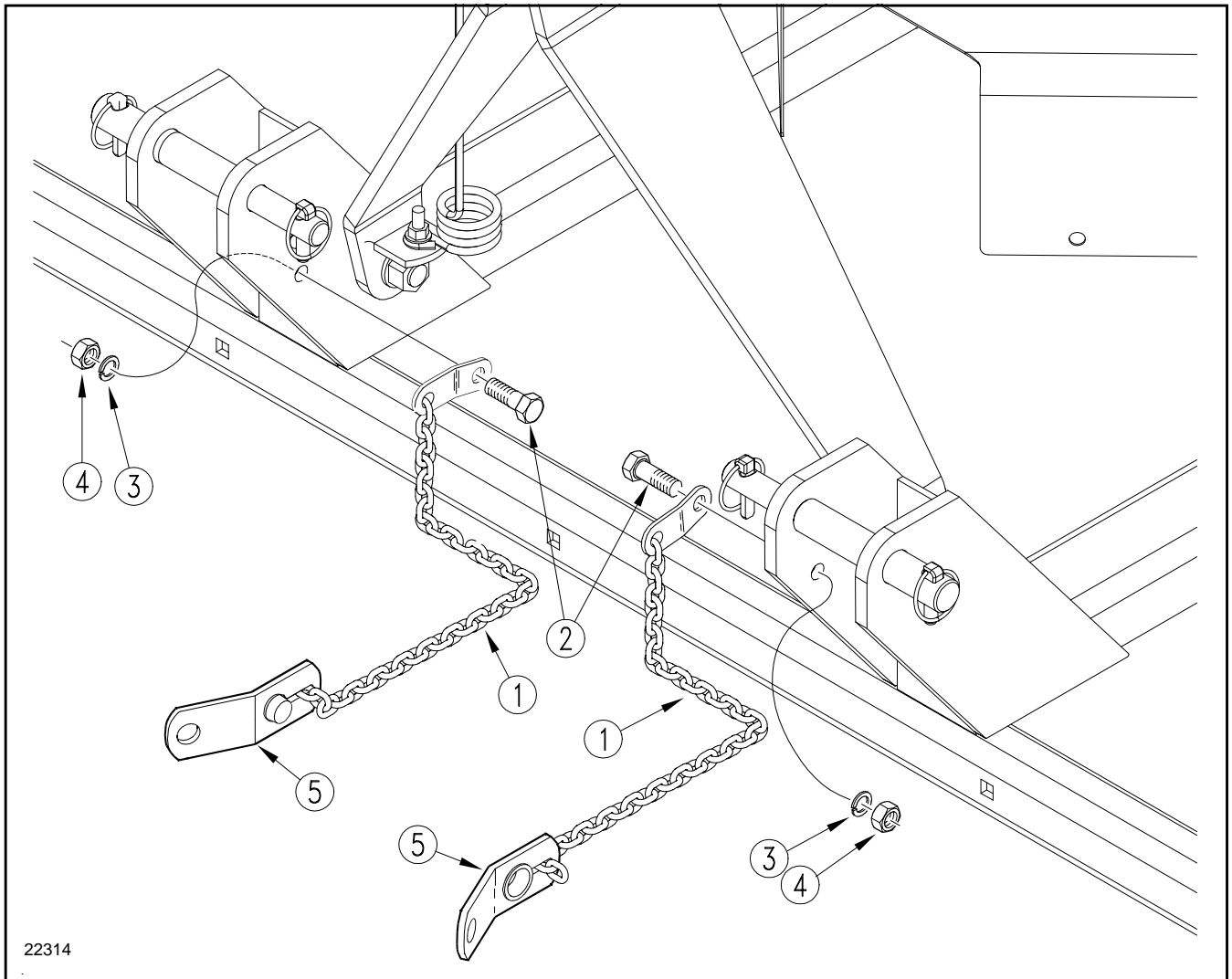

Check Chain Assembly
Figure 1-18

Section 2: Adjustments

Leveling Procedure

Lift-type and Pull-Type cutters must operate level from side to side at all times. Gauge wheels should be set at identical heights.

Lift-Type Cutter

There are four primary adjustments that should be made prior to actual field operations:

- a. Deck level from left to right
- b. Tractor top link length
- c. Tractor lower link height
- d. Tailwheel height

Proper adjustment of each of these items will provide for higher efficiency, improved cutting performance and longer blade life. The following tools will be needed:

- a. Pliable tape measure
- b. Spirit or carpenter's level
- c. Open end or hex end wrench or socket set
- d. Protective gloves

Refer to Figure 2-1:

1. Having completed the “**Tractor Hook-up**”, locate the tractor on a flat, level surface.
2. Use the tractor's hydraulic 3-point control to lower the cutter until the tailwheel contacts ground surface.
3. Place a spirit level or other suitable leveling device on the front of the cutter deck as shown. Adjust either one or both of the tractors lower link height adjustments to level the deck from left to right. Some tractors have only a single adjusting crank.
4. Similarly, place a level on either of the main deck channels. Shorten or lengthen the tractor's top center link to level the cutter deck from front to rear.

NOTE: The unit cuts most efficiently if the front of the cutter is slightly lower than the back.

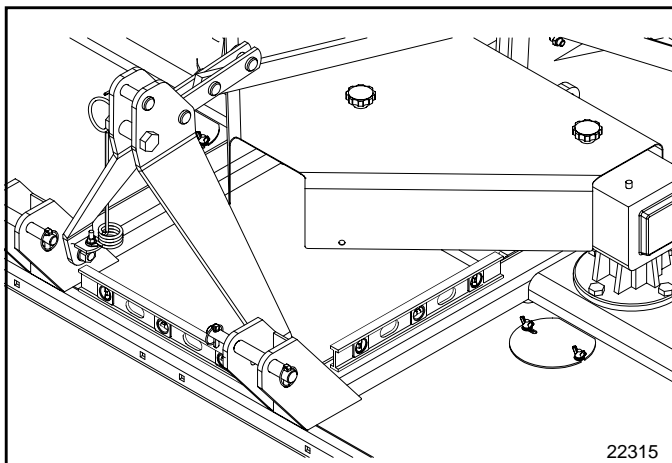

Deck Leveling
Figure 2-1

Pull-Type Cutter

There are two primary adjustments that should be made prior to actual field operations:

- a. Deck level from left to right
- b. Cutting height

Proper adjustment of each of these items will provide for higher efficiency, improved cutting performance and longer blade life. The following tools will be needed:

- a. Pliable tape measure
- b. Spirit or carpenter's level
- c. Open end or hex end wrench or socket set
- d. Protective gloves

Refer to Figure 2-2:

1. Having completed “**Tractor Hook-up**”, locate tractor and cutter on a flat, level surface.
2. Use tractor's hydraulics to adjust deck height above ground level 2 to 3 inches.
3. Place a spirit level (#3) or other suitable leveling device on either of the main deck channels.

NOTE: The unit cuts most efficiently if the front of the cutter is slightly lower than the back.

Lengthening leveling rods with adjusting nuts (#2) lowers the front of the cutter.

4. If cutter deck is not slightly lower at the front than at the back, then loosen jam nuts (#1) on both sides and rotate leveling rod adjusting nuts (#2) until deck is slightly lower by an equal amounts on both sides.
5. Be sure that the right and left leveling rods are equally tight and then re-tighten jam nuts (#1).

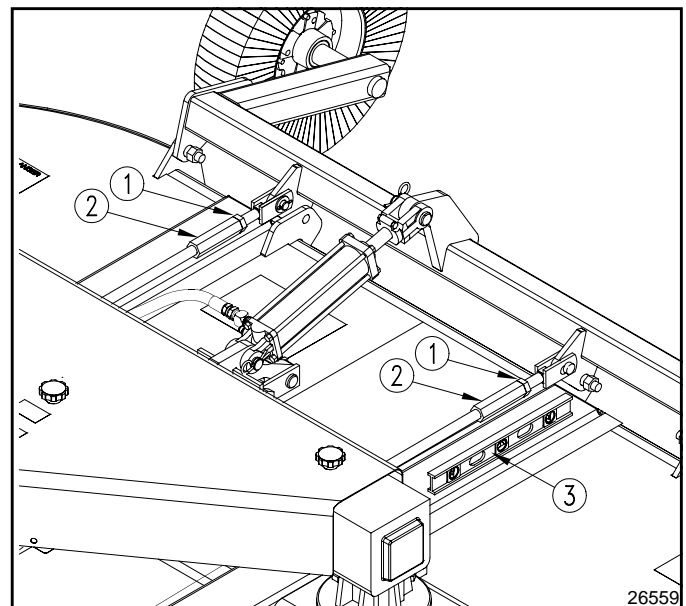

Deck Leveling
Figure 2-2

Section 2: Adjustments

Cutting Height Adjustment



DANGER!

Engage parking brake, disengage PTO, shut off tractor and remove key before proceeding. Ensure that all moving parts have come to a complete stop before dismounting from the tractor.



CAUTION!

Wear a pair of gloves when performing this operation. Go to the back of the cutter and carefully rotate each blade to the position shown in Figure 2-3. Avoid direct contact with the cutting edge of the blade.

Refer to Figure 2-3:

Measure distance from cutting tip of the front cutting blade to ground surface. This distance is the cutting height.

Lift-Type Cutter

Refer to Figure 2-4:

Adjust the tailwheel if cutting height is too high or too low.

1. Use tractor's 3-point hydraulic control to lift cutter so that the tailwheel clears the ground.
2. Remove existing hardware; 1/2" -13 x 1 1/2" long carriage bolt (#1) and 1/2" flange nut (#2).
3. Adjust tailwheel up or down to desired cutting height by repositioning adjusting plate (#3) and then replacing the hardware.
4. Tighten 1/2" flange nut (#2) to the correct torque. Refer to "Torque Values Chart for Common Bolt Sizes" on page 38.

Pull-Type Cutter

Refer to Figure 2-5:

Lift mechanism for pull-type units can be equipped with either a ratchet jack (#1) or hydraulic cylinder (#2). Adjust lifting mechanism if cutting height is too high or too low.

Ratchet Jack Instructions

The deck can be raised or lowered by setting the ratchet mechanism on the ratchet jack (#1) and then pumping the jack handle to raise or lower the cutter to desired cutting height.

Hydraulic cylinder Instructions

Stroke control spacers (#3) are included with the hydraulic set-up. They consist of cast steel halves with spring clips to hold the two halves together.

1. Extend the hydraulic cylinder to free up space on the cylinder rod for installing and removing spacers. Add or remove spacers as needed.
2. Retract hydraulic cylinder and re-measure to verify if cutting height is suitable.
3. Store stroke control spacers on hydraulic hose (#4) near the hydraulic cylinder.

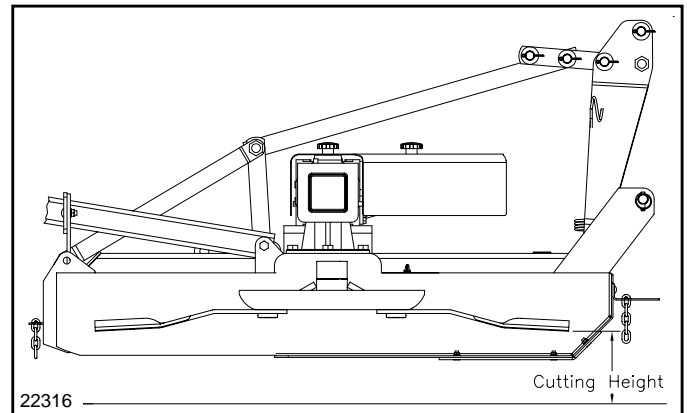

Cutting Height
Figure 2-3

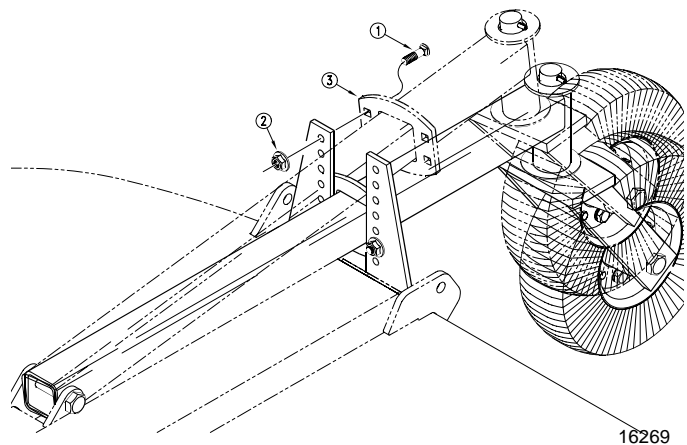

3-Point Cutter Height Adjustment
Figure 2-4

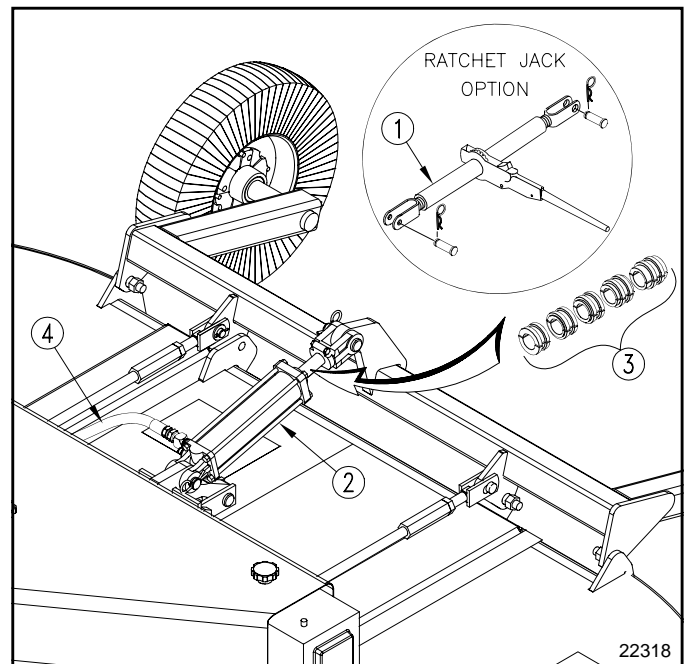

Pull-Type Lift Selections
Figure 2-5

Section 3: Operating Procedures

Operating Check List

It is absolutely essential that no one operates the Rotary Cutter without first having read, fully understood and become totally familiar with the Operator’s Manual. Make sure the operator has paid particular attention to:

- **Important Safety Information**, pages 1 to 7
- **Section 1: Assembly and Set-Up**, page 10
- **Section 2: Adjustments**, page 22
- **Section 3: Operating Procedures**, page 24
- **Section 4: Maintenance & Lubrication**, page 28

In addition to design and configuration of equipment, hazard control and accident prevention are dependent upon the awareness, concern, prudence and proper training involved in the operation, transport, maintenance and storage of equipment. Before beginning to cut, the following inspection should be performed.

Operating Checklist

Check	Reference
<input type="checkbox"/> “Important Safety Information” in this Manual.	Page 1
<input type="checkbox"/> Check oil level in gearboxes.	Section 3 Page 32
<input type="checkbox"/> Check that all plugs in gearbox have been replaced properly.	Section 3 Page 32
<input type="checkbox"/> Be sure nuts and bolts are tight.	Section 7
<input type="checkbox"/> Be certain all guards and shields are in place.	Section 1 Page 15
<input type="checkbox"/> Lubricate the cutter as needed. Refer to “Maintenance and Lubrication”.	Section 4 Page 28

Make the following inspections after hooking-up to the cutter. See hook-up instructions beginning on page 17. Make certain the PTO is disengaged and completely stopped before continuing.

1. Inspect tractor safety equipment to make sure it is in good working condition.
2. Carefully raise and lower implement to ensure that the drawbar, tires, and other equipment on the tractor do not contact the cutter frame or PTO driveline.
3. Check all hoses and wires to be sure that they will not contact PTO driveline. Check PTO guards to make certain they are in good condition and in place.
4. Inspect Hydraulic hoses for wear, damage and hydraulic leaks. See “Avoid High Pressure Fluids Hazard” on page 3. Replace damaged and worn hoses with genuine Land Pride parts.
5. With the PTO disengaged and completely stopped, check cutting blades for sharpness.
6. (Lift-Type Cutter) Adjust tractor lower 3-point arms such that the PTO driveline is approximately level.

IMPORTANT: Stop PTO immediately if vibration continues after a few revolutions during start-up and anytime it occurs thereafter. Wait for PTO to come to a complete stop before dismounting from tractor to check for probable causes. Make necessary repairs and adjustments before continuing on.

7. Start tractor, set throttle to idle or slightly above idle and slowly engage the PTO. Initial start-up vibration is normal and should stop after a few revolutions. Stop PTO rotation immediately if vibration continues.

IMPORTANT: Do not exceed rated PTO speed of the cutter. Excessive engine speed will cause damage to the power train components.

8. Once the cutter is running smoothly, increase tractor PTO speed to 540 RPM. Stop PTO rotation immediately if vibration occurs.

Transporting the Cutter



CAUTION!

When traveling on public roads at night or during the day, use accessory lights and devices for adequate warning to operators of other vehicles. Comply with all federal, state and local laws.

IMPORTANT: Always disengage the tractor’s PTO before raising the cutter to transport position.

1. Make sure driveline does not contact tractor or cutter when raising cutter to the transport position.
2. Reduce tractor ground speed when turning and leave enough clearance so cutter does not contact obstacles such as buildings, trees or fences.
3. Limit transport speed to 20 mph. Transport only with a farm tractor of sufficient size and horse power.
4. When traveling on roadways, transport in such a way that faster moving vehicles may pass you safely.
5. Shift tractor to a lower gear when traveling over rough or hilly terrain.

Un-hooking the Cutter

The following steps should be done when un-hooking the cutter from the tractor.

1. Park on a level solid surface.
2. Shut tractor engine off and engage parking brake.
 - Lift-Type: Lower deck to level ground or onto blocks supporting deck just above ground level.
 - Pull-Type: See Pull-Type Tractor Un-Hook on page 20.
3. Unhitch from tractor.
4. See “Storage Instructions” on page 31 if cutter is not going to be used for a long time.

Section 3: Operating Procedures

Cutting Instructions



DANGER!

The use of front & rear safety shields is strongly recommended to prevent injury or death caused by thrown objects! Gearbox shields must be secured in place when operating to avoid injury or death from entanglement in rotating drivelines.



DANGER!

Rotary Cutters have the ability to discharge objects at high speeds. Therefore, the use of front & rear safety guards is strongly recommended to prevent injury or death caused by thrown objects!



CAUTION!

Damage may occur if exceeding the rated cutting capacity of the cutter!



CAUTION!

Do not over speed PTO or machine damage may result. The 8' model in this series is available in 540 RPM. The 10' model in this series is available in 540 RPM or 1000 RPM. Know what your tractor requirements are.



WARNING!

The RCR25 series cutter is designed to cut grass and brush up to 1" in diameter. Using this cutter for any other type of work can damage the drive components, deck and support frame.



DANGER!

Do not use deck as a fan. Cutting blades are not properly designed or guarded for this use. Using the deck as a fan can result in injury and/or death.



DANGER!

Do not operate and/or travel across steep inclines where a tractor can roll-over resulting in serious injury or death. Consult your tractor's manual for acceptable inclines the tractor is capable of traveling across.



CAUTION!

Tractor PTO shield and all Rotary Cutter guards must be in place at all times during operation!

IMPORTANT: Avoid catching the hydraulic hoses on brush, post, stumps, and other protrusions that could damage and/or break them.

NOTE: Your cutter is equipped with free swinging cutting blades to reduce shock loads to the cutter if striking obstacles.

This cutter was designed to cut grass and medium brush in right-of-ways, pastures and for shredding row crop residues.

1. Thoroughly Inspect the area to be cut for debris and unforeseen objects. Mark any potential hazards.
2. Start machine slowly allowing cutter blades to become aligned properly before going to full power.
3. It is important to maintain correct RPM PTO speed. Loss of PTO speed will allow blades to hinge back and result in ragged, uneven cutting.
4. Never run fast enough to overload the tractor or cutter. Ground speed depends on two things:
 - The density of material being cut.
 - Size of tractor operating the cutter.
5. After the first 50 feet, stop and check to see that the cutter is adjusted properly.
6. Do not engage PTO with 3-point in the fully raised or position.
7. Periodically disengage PTO, turn off tractor, remove ignition key and check for foreign objects wrapped around the rotor shaft. Block cutter deck up before removing objects.

Turning Angles for Pull-Type Cutters

Refer to Figure 3-1 and 2-3:

Avoid tractor-to-cutter turning angles exceeding 35 degrees if the main driveline is a standard conventional drive shaft. The turning angle may be increased to 80 degrees if equipped with a constant velocity driveline shaft. These extreme angles are intended for intermittent usage only and not prolonged usage. Plan your field cutting to minimize the number of turns as well as extreme angles where turns are necessary.

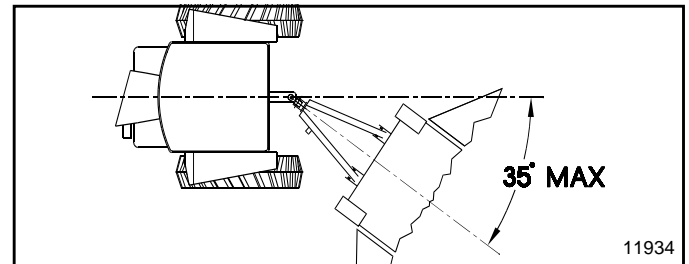

Conventional U-Joint Driveline

Figure 3-1

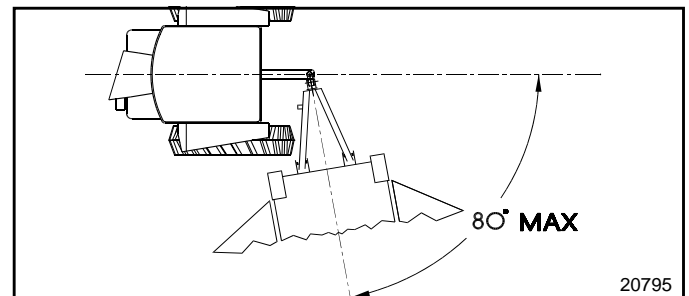

CV Driveline

Figure 3-2

Section 3: Operating Procedures

Crossing Steep Ditches & Banks

Refer to Figure 3-3:



WARNING!

Damage to the tractor's PTO components and/or driveline components can cause the driveline to come loose and cause bodily injury to the operator and others.

IMPORTANT: Always cross steep ditches and banks at a diagonal. Never cross straight across a steep ditch or bank and never back into a steep ditch or bank.

Cutting over ditches and backing up hills can tilt the cutter's back side up excessively resulting in "Bottoming Out" the driveline. Bottoming out is when the driveline shaft has shorten to the point it is pressing against the gearbox and tractor PTO shafts. Once a driveline has bottomed out, it can not be shorten anymore without causing serious damage to the tractor PTO components, cutter gearbox and driveline.

Do not operate a pull-type cutter at an angle exceeding 25 degrees up or down or at any angle that will force the driveline to bind and/or hit the tractor drawbar.

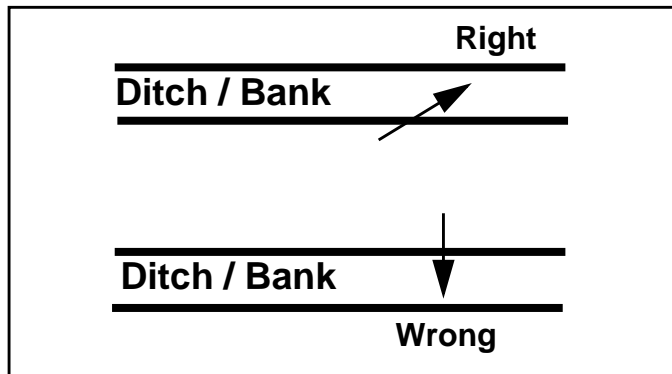

Crossing Steep Ditches and Banks
Figure 3-3

General Operating Instructions

Now that you have familiarized yourself with the Operator's Manual, completed the Operators Checklist, properly attached your Cutter to your tractor, made the right leveling adjustments, and preset your cutting height, you're almost ready to begin using your Land Pride Rotary Cutter.

It's now time to do a running operational safety check. Shut the tractor off immediately and remove the key if at any time during this safety check you detect a malfunction in either the cutter or tractor. Make necessary repairs or adjustments before continuing on.

If you have a three-point hitch model make sure the tractor's park brake is engaged, the tractor's PTO is disengaged, and the cutter is resting on the ground. Start

the tractor and then back the tractor throttle off until the engine is at low idle. With the tractor's rear hydraulic lift control lever, raise the cutter to transport position making sure that the PTO shaft is not in a bind and does not come in contact with the cutter frame. Lower the cutter to the ground and, with the tractor still at low idle, engage the PTO. If everything is running smoothly at this point increase the engine rpm until the tractor's engine reaches full PTO operating speed. The RCR2596 and RCR2510 will be 540 rpm only while the RCRM2510 is designed to operate at 1000 rpm PTO speed. Slowly raise the cutter to transport height to make sure the driveline does not bind or chatter. Then return the engine to low idle, disengage the PTO, and position the adjustable stops on the tractor's hydraulic lift lever so the cutter can be consistently returned to the same cutting and transport height.

If you have a pull-type cutter, make sure the park brake is on and the cutter is on the ground in mowing position. Start the tractor and reduce engine speed to low idle. Engage the PTO and increase engine rpm until you reach full PTO speed. If everything is running smoothly your running safety check is complete and you may shut the tractor and cutter off.

You should now be ready to move to the cutting site to begin mowing. You should have inspected and should only be cutting in an area you are familiar with which is free of debris and unseen objects. Never assume an area is clear and extremely tall grass should be cut twice to detect potential hazards. In the event you do strike an object stop the tractor and cutter immediately to inspect the cutter and make any necessary repairs before resuming operation. It pays to inspect a new area and to develop a plan before you cut.

Normal mowing speed will be between 2-5 mph and you will need to maintain 540 rpm PTO speed to produce a clean cut, so make a tractor gear and range selection that will maintain this combination. Generally the quality of cut will be better at lower ground speeds and cutting denser ground cover will create the need to slow down. In certain conditions tractor tires will roll grasses down resulting in an uneven cutting height when the grass fails to rebound before being cut. When this happens you may need to reverse the cutting direction and double cut to achieve the desired finish. You will want to avoid very low cutting heights especially on extremely uneven terrain. Always cut downward on slopes and avoid crossing the face of steep slopes. Avoid sharp drops and cross diagonally through dips to prevent hanging up the tractor and cutter. Slow down in turns and avoid sharp turns if at all possible. Remember to look back often.

Now you're prepared and well briefed so lets begin cutting. Reduce the tractor's engine rpm, make sure the cutter is on the ground and in cutting position, engage the PTO, raise the engine rpm to the appropriate PTO speed, and begin mowing. When it is difficult to make a wide turn and you need to reverse direction, the three point hitch models can be lifted into transport position to make a

Section 3: Operating Procedures

tight turn. Operators of pull-type models must plan ahead and choose a cutting pattern that allows for wider turns. Try increasing or decreasing ground speed to determine the effect on quality of cut. With a little practice you will be pleased with what you and your Land Pride Cutter can do.

When you are done mowing, need to take a break, or just need to make a few adjustments to the cutter, remember to always do the following: reduce the tractor's engine rpm, disengage the PTO, stop on level ground, set the park brake, turn off the engine and remove the key.

See "**Features and Benefits**" section or "**Product Specifications**" for additional information and performance enhancing options.

Section 4: Maintenance & Lubrication

Maintenance

Proper servicing and adjustment is the key to the long life of any implement. With careful and systematic inspection, you can avoid costly maintenance, time and repair.

After using your cutter for several hours, check all bolts to be sure they are tight.

Replace any worn, damaged or illegible safety labels by obtaining new labels from your Land Pride Dealer.

Service Cutting Blades



DANGER!

Always disconnect main driveline from tractor PTO before servicing the underside of the cutter deck. Cutter can be engaged if tractor is started resulting in damage to the cutter, bodily injury and/or death.



WARNING!

Always secure cutter deck in the up position with solid supports before servicing the underside of the cutter. Never work under equipment supported by hydraulics. Hydraulics can drop equipment if controls are actuated or if hydraulic lines burst. Either situation can drop the cutter instantly even when power to the hydraulics is shut off.

IMPORTANT: Replace cutting blades with genuine Land Pride blades only. Blades must be replaced in mating pairs. Not replacing both blades will result in an out-of-balance condition that will contribute to premature bearing break down on the spindle hub and create structural cracks in cutter housing.

Always inspect cutting blades before each use. Make certain they are properly installed and are in good working condition. Replace any blade that is damaged, worn, bent, or excessively nicked. Small nicks can be ground out when sharpening.

1. Place tractor gear selector in park and/or set brakes, shut engine off and remove ignition key.
2. Disconnect main driveline from tractor PTO and secure cutter deck in the up position with solid supports before servicing underside of cutter.
3. Inspect cutting blades. Make certain they are properly installed and are in good working condition. Replace any blade that is damaged, worn, bent, or excessively nicked. Small nicks can be ground out when sharpened.
4. To remove blades from the cutter, align blade bolts with blade bolt access hole located in the deck.
5. Both blades should be sharpened at the same angle as the original cutting edge and must be replaced or re-ground at the same time to maintain proper

balance. The following precautions should be taken when sharpening blades:

- a. Do not remove more material than necessary.
- b. Do not heat and pound out a cutting edge.
- c. Do not grind blades to a razor edge. Leave a blunt cutting edge approximately 1/16" thick.
- d. Always grind cutting edge so end of blade remains square to cutting edge and not rounded.
- e. Do not sharpen back side of blade.
- f. Both blades should weigh the same after sharpening with not more than 1 1/2 oz. difference.

Refer to Figure 4-1:

6. Make certain when installing cutter blades that the blades on one spindle is positioned 90 degrees to the blades on the other spindle as shown in Figure 4-1.
7. Carefully check cutting edges of blades in relation to blade carrier rotation to ensure correct blade placement. Blade rotation is counterclockwise on the left side and clockwise on the right side as shown. Airfoil (lift) must be oriented towards the top of the deck.

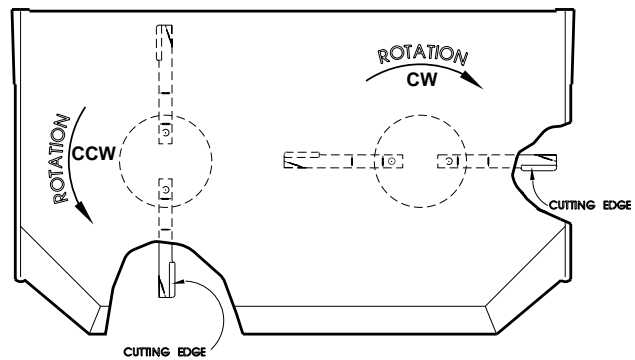

REAR OF CUTTER

Blade Positioning and Rotational Directional
Figure 4-1

Refer to Figure 4-2:

IMPORTANT: Examine blade bolts (#1) and washers (#5) for excessive wear and replace if worn.

IMPORTANT: Locknuts can lose their ability to lock properly once removed. Therefore, always use a used blade nut or plain nut in steps 8 & 9 below and then **replace used nut with new locknut in step 10.**

8. Start by assembling blades without shim (#2). Insert blade bolt (#1) through blade (#3), dish pan (#4) and flat washer (#5). Temporary secure blade with a used 1 1/8"-12 nut. **Draw nut up snug. Do not tighten.**

Section 4: Maintenance & Lubrication

9. Check blade deflection. If deflection is greater than 3/4", remove blade bolt and reassemble as before except include shim (#2) in the assembly. Select shim thickness based on deflection. The greater the deflection, the thicker the shim.
10. Once blade deflection is correct, **replace used nut with new locknut (#6)** and torque to 450 ft-lbs.
11. If replacing dishpan (#4), nut on gearbox output shaft should be torqued to 450 ft-lbs. minimum and cotter pin installed in nut with legs securely bent around nut.

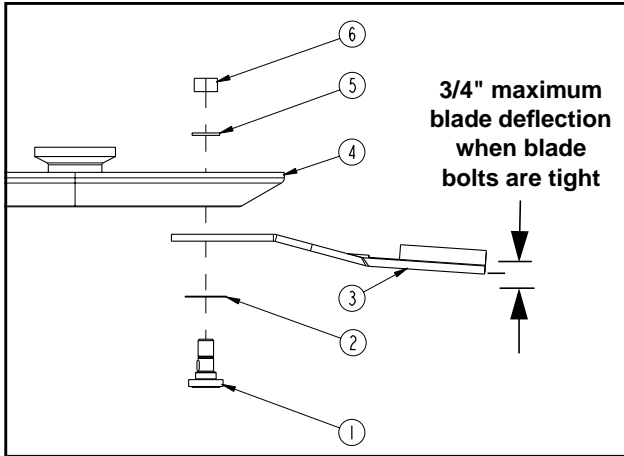

Cutter Blade Assembly
Figure 4-2

Land Pride Cutter Blade Parts

Item	Part No.	Part Description
	318-586A	BLADE BOLT KIT (Includes items 1, 2, 5, & 6 below)
1	802-277C	BLADE BOLT 1 1/8-12 x 3 7/16 WITH KEY
2	312-075D	BLADE SPACER 16 GA. (.060")
2	312-082D	BLADE SPACER 18 GA. (.048")
2	312-089D	BLADE SPACER 20 GA. (.036")
2	312-808D	BLADE SPACER 24 GA. (.024")
3	-----	SEE LIST OF CUTTER BLADES BELOW
4	312-881H	27 x 10G OVAL DISHPAN WELDMENT
5	804-147C	WASHER FLAT 1 HARD ASTMF436
6	803-170C	NUT HEX TOP LOCK 1 1/8-12 PLATE

Land Pride List of Cutter Blades

Part No.	Part Description
820-195C	RCR2596 CUTTER BLADE 1/2 x 4 x 20 CCW
820-196C	RCR2596 CUTTER BLADE 1/2 x 4 x 20 CW
820-137C	RCR2510 CUTTER BLADE 1/2 x 4 x 25 CCW
820-112C	RCR2510 CUTTER BLADE 1/2 x 4 x 25 CW

Optional Low Lift Cutter Blades

820-210C	RCR2596 BLADE 1/2X4X20.5 LL CCW
820-211C	RCR2596 BLADE 1/2X4X20.5 LL CW
820-193C	RCR2510 BLADE 1/2X4X25 LL CCW
820-209C	RCR2510 BLADE 1/2X4X25 LL CW

Driveline Protection

Cutter drive components are protected from shock loads by a friction slip-clutch. The clutch must be capable of slippage during operation to protect the gearbox, driveline and other drive train parts.

Clutch Run-In

Friction clutches should be "run-in" prior to initial operation and after long periods of inactivity to remove any oxidation that may have accumulated on friction surfaces. To prevent driveline and gear box damage, repeat "run-in" instructions at beginning of each season and when moisture and/or condensation seizes inner friction plates.



CAUTION!
Engage parking brake, disengage PTO, shut off tractor, and remove key before making any of the following adjustments.

Refer to Figure 4-3:

1. Using a pencil or other marker, scribe a line across the exposed edges of the clutch plates and friction discs.

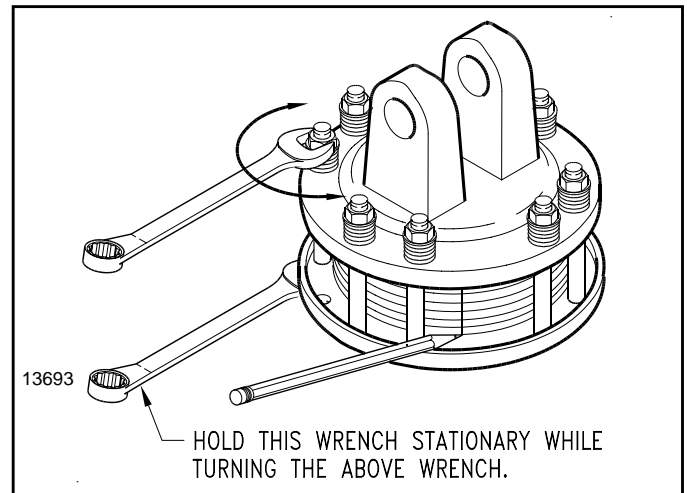

Clutch
Figure 4-3

2. Carefully loosen each of the 8 spring retainer nuts on the clutch housing a total of EXACTLY 2 revolutions. It will be necessary to hold the hex end of the retainer bolt in order to count the exact number of revolutions.
3. Start tractor and engage driveline for 2-3 seconds to permit slippage of the clutch surfaces. Disengage the PTO, then re-engage a second time for 2-3 seconds. Disengage the PTO, shut off tractor and remove key. Wait for all components to stop before dismounting from tractor.
4. Inspect clutch and ensure that scribed markings made on the clutch plates have changed position. Slippage has not occurred if any two marks on the friction disc and plate are still aligned.

Section 4: Maintenance & Lubrication

IMPORTANT: The clutch must be disassembled into separate friction discs if one or more friction disc did not slip during clutch run-in operation. See Clutch Disassembly on page 30.

5. Tighten each spring retainer nut on the clutch housing exactly 2 revolutions to restore clutch to original setting pressure. See Clutch Assembly on page 30 for exact spring length.
6. The clutch should be checked during the first hour of cutting and periodically each week. An additional set of scribe marks can be added to check for slippage.

Clutch Disassembly

Refer to Figure 4-4:

Disassembly of the clutch is simply a matter of removing the spring retainer nuts (#1), springs (#2) and bolts (#3) from the assembly. Each friction disc (#4) must then be separated from the metal surface adjacent to it.

Clutch Inspection

Inspect all parts for excessive wear and condition. Clean all parts that do not require replacement. The original friction disc thickness is 1/8" (3.2 mm) and should be replaced if thickness falls below 3/64" (1.1 mm). If clutches have been slipped to the point of "smoking", the friction discs may be damaged and should be replaced. Heat build-up may also affect yoke joints.

Clutch Assembly

Refer to Figure 4-4:

Install new friction discs if needed and reassemble all components in proper order. Reassemble each friction disc (#4) next to the metal plate it was separated from. Install bolts (#3) through the end plates and intermediate plates as shown. Place springs (#2) over the bolts and secure with nuts (#1).

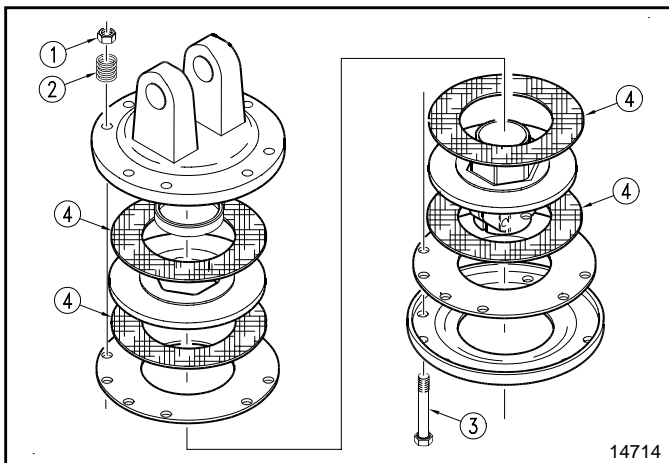

**4-Plate Slip Clutch Assembly (540 RPM Shown)
Figure 4-4**

Refer to Figure 4-5:

Progressively tighten each spring retainer bolt until correct spring height "A" is reached. See Tables below Figure 4-5.

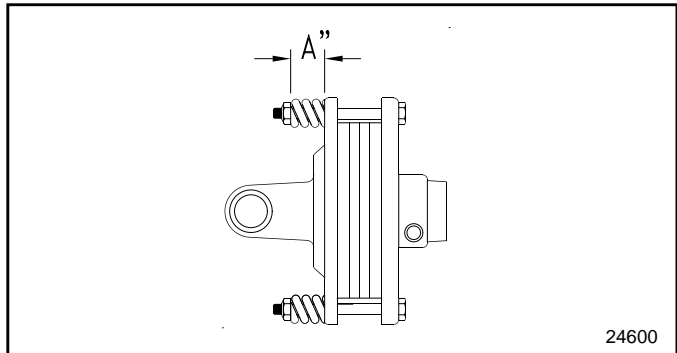

**Clutch Adjustment
Figure 4-5**

RCR2596

Driveline No.	Driveline Location	PTO Speed	Cat No.	A (inches) Spring Height
826-255C	Main	540	4	1.175" (S/N 566919+)
826-256C	Jack Shaft			1.12" (S/N 566918-)

RCR(M)2510

Driveline No.	Driveline Location	PTO Speed	Cat No.	A (inches) Spring Height
826-215C	Main			1.175" (S/N 566919+)
826-220C	Jack Shaft	540	4	
826-225C	Stub Shaft			1.12" (S/N 566918-)
826-216C	Main			1.09" (S/N 566919+)
826-221C	Jack Shaft	1000	4	
826-226C	Stub Shaft			1.02" (S/N 566918-)

Section 4: Maintenance & Lubrication

Flex Couplers

Refer to Figure 4-6:

Replace rubber disc (#6) as follows:

1. Insert 3-bolts (#1) through the holes in flange weldment (#7).
2. Place beaded washers over the 3-bolts with bead facing rubber disc (#6).
3. Place bushings (#3), rubber disc (#6) and washers (#4) over the 3-bolts as shown.
4. Secure with nuts (#5). Do not tighten.
5. Insert 3-bolts (#1) through the holes in flanged hub (#8).
6. Repeat steps 2 through 4.
7. Tighten nuts (#5) evenly with nuts torqued 35 to 40 ft-lb. Beaded washers (#2) should be imbedded halfway into the rubber disc.

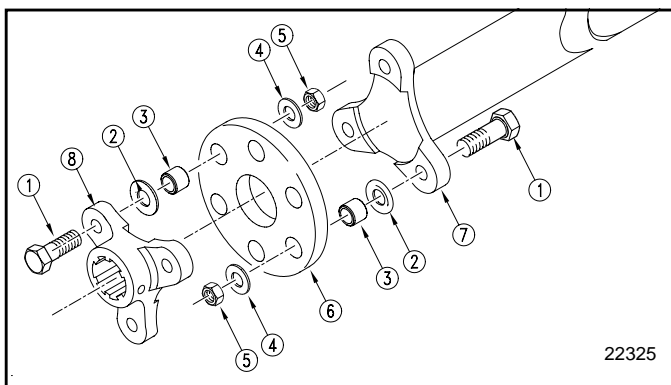

Flex Couplers
Figure 4-6

Skid Shoe Maintenance

Refer to Figure 4-7:

! WARNING!

Excessive wear on skid shoes may cause inadequate operation of cutter and create a safety hazard!

There are two skid shoes mounted on the cutter sides. Check both skid shoes for wear and replace if necessary. Order only genuine Land Pride parts from your local Land Pride Dealer.

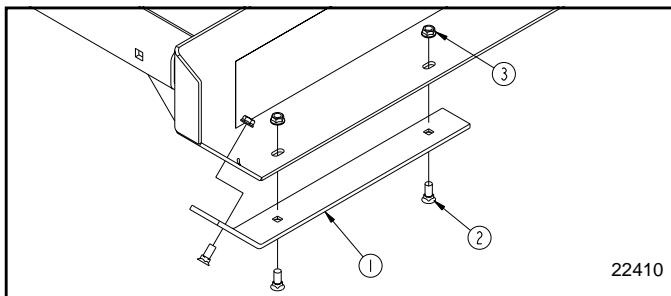

Skid Shoe Replacement
Figure 4-7

Land Pride Skid Shoe Replacement Parts

Part No.	Part Description
312-602D	SKID SHOE
802-603C	PLOW 3/8-16 x 1 GR5
803-198C	NUT HEX WHIZ 3/8-16 PLT

1. Remove 3/8" hex whiz nuts (#3), 3/8" plow bolts (#2) and skid shoe (#1) as shown.
2. Plow bolts should be checked for wear and replaced if necessary.
3. Attach new skid shoe (#1) to cutter with existing 3/8" plow bolts (#2) and secure with 3/8" hex whiz nuts. Torque to 31 ft. lbs.
4. Repeat on opposite side.

Tractor Maintenance

One of the most important things you can do to prevent hydraulic system problems is to ensure that your tractor's reservoir remains free of dirt and contamination.

Use a clean cloth to wipe the hose ends before attaching them to your tractor. Replace the filter element for your tractor's hydraulic system at the prescribed intervals. These simple maintenances will go a long way to prevent the occurrence of cartridge valve and hydraulic cylinder problems on the Rotary Cutter.

Storage Instructions

It is good practice to clean off any dirt or grease that may have accumulated on the cutter and moving parts at the end of the working season and when the cutter will not be used for a long time.

! DANGER!

Always disconnect main driveline from tractor PTO and secure cutter deck in the up position with solid supports before servicing the underside of the cutter.





1. Clean the cutter as necessary.
2. Check the blades for wear and replace if necessary, see "Service Cutting Blades", Page 28.
3. Inspect the cutter for loose, damaged or worn parts and adjust or replace as needed.
4. Lubricate as noted in "Lubrication", page 32.
5. Store the cutter inside if possible for longer cutter life.
6. Repaint parts where paint is worn or scratched to prevent rust. Ask your dealer for Aerosol Land Pride touch-up paints.

Land Pride Touch-up Paints



Part No.	Part Description
821-011C	PAINT LP BEIGE SPRAY CAN
821-002C	PAINT GP BLACK SPRAY CAN
821-054C	PAINT MEDIUM RED SPRAY CAN
821-058C	PAINT GREEN SPRAY CAN

Section 4: Maintenance & Lubrication

Lubrication Points

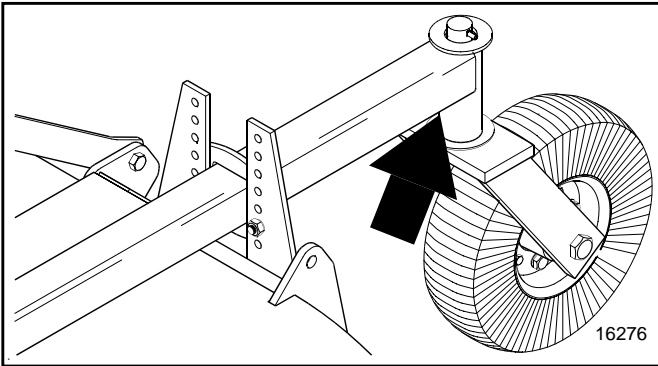
Lubrication Legend	 Multi-purpose spray lube	 Multi-purpose grease lube	 Multi-purpose oil lube	 50 Intervals in hours at which lubrication is required
---------------------------	--	---	---	--



	 24 Hours
--	--



Tailwheel Spindle Tube

Lift-Type Cutter

Type of Lubrication: Grease

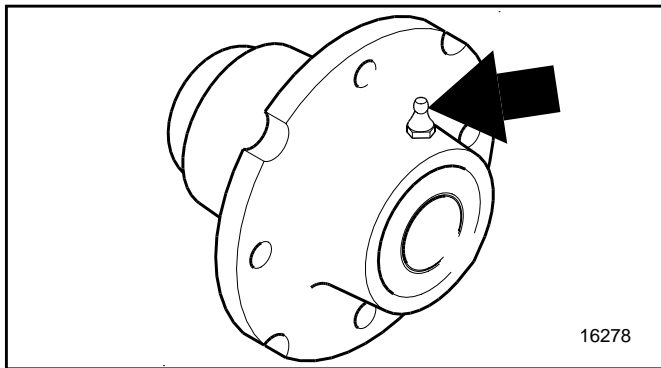
Quantity = 6 pumps



	 8 Hours
--	---

Tailwheel Hub

The tailwheel hub is equipped with a relief hole located directly opposite the grease fitting. The relief hole releases pressure from inside the hub casting when it is greased. The hub should be greased until grease purges from the relief hole.

Type of Lubrication: Multi-purpose Grease

Quantity = Until grease purges from the relief hole

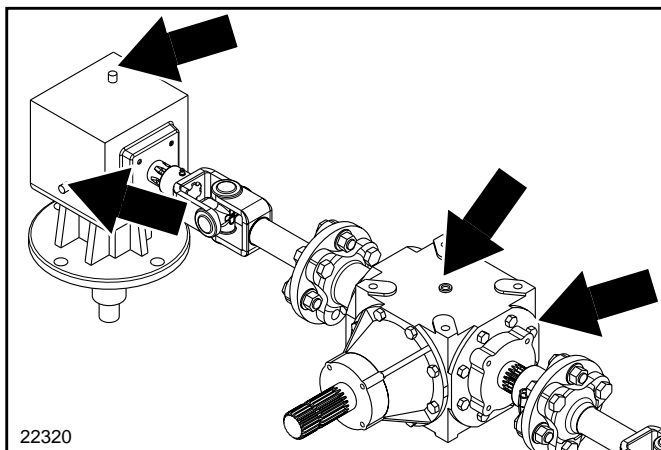

	 8 Hours
--	---

Gearbox & T-Box

Check oil level in the gearbox by removing the side plug in the gearbox case. If the oil level is low, remove the top plug in the gearbox case and fill with 80-90W EP oil until oil flows from the side port of gearbox case. Reinstall plugs and tighten.

NOTE: Do not overfill! Cutter should be level when checking oil.

Type of Lubrication: 80-90W EP Oil

Quantity = Fill until oil flows from the side port of gearbox case.

Section 4: Maintenance & Lubrication

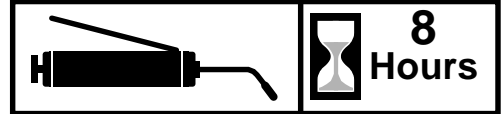
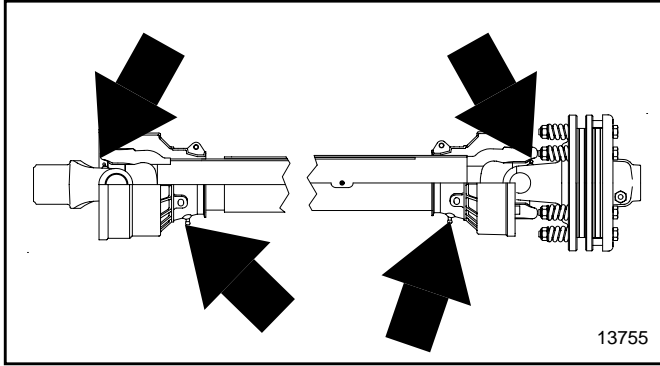

Driveline U-Joints

Type of Lubrication: Grease

Quantity = 6 pumps

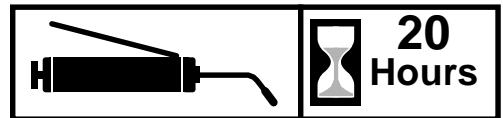
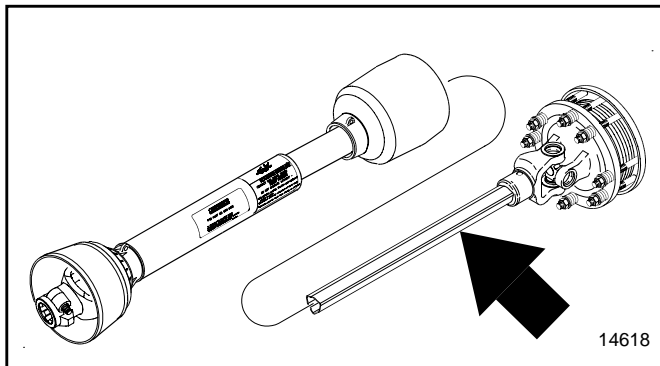

Driveline

Quantity = Clean & coat the inner tube of the driveline with a light film of grease and then reassemble.

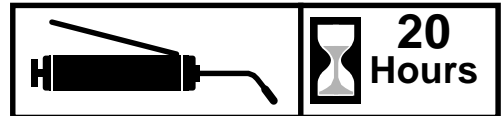
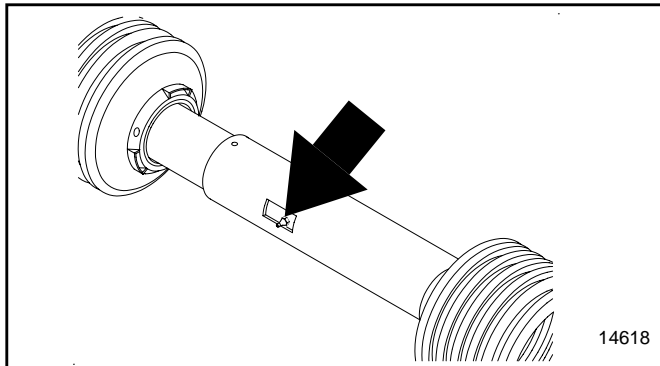

Constant Velocity Driveline

Quantity = Clean & coat the inner tube of the driveline with a light film of grease and then reassemble.

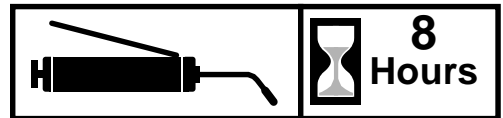
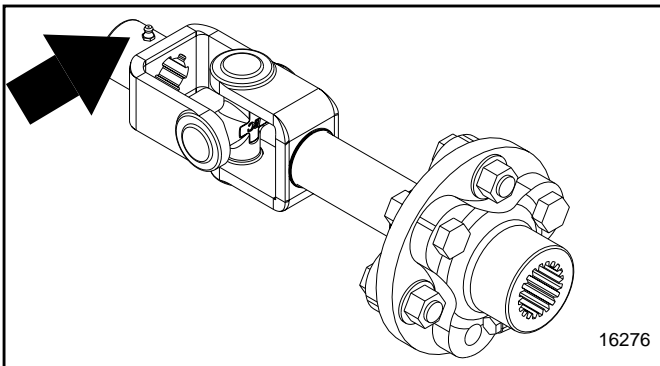

Flex Coupler

Type of Lubrication: Grease

Quantity = As required

Section 4: Maintenance & Lubrication

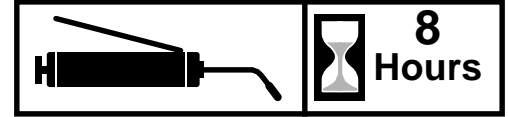
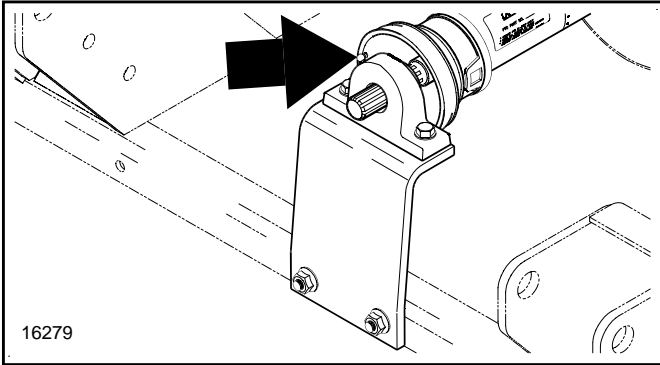

Pillow Bearing (Pull-Type Cutter)

(RCR2510 & RCRM2510)

Type of Lubrication: Grease

Quantity = As required

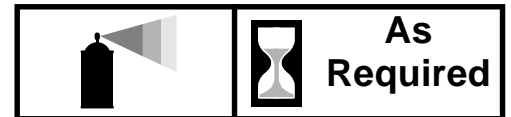
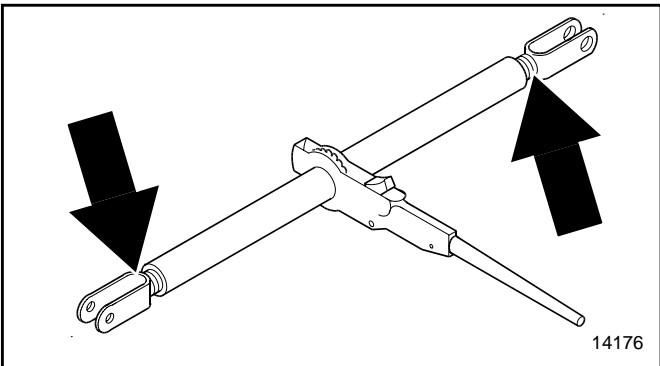

Ratchet Jack

Type of Lubrication: Multi-Purpose

Quantity = As required

Section 5 Specifications & Capacities

RCR2596, RCR2510 & RCRM2510 Models		
	RCR2596 (540 RPM)	RCR2510 (540 RPM) RCRM2510 (1000 RPM)
Hitch	Lift-Type Category 1 & 2 Quick hitch adaptable Pull-Type - w/Dual Level Rods	Lift-Type Category 2 & 3 Quick-Hitch adaptable Pull-Type - w/Dual Level Rods
Working Width	94"	118"
Overall Width	100"	123.5"
Overall Length	Lift-Type: 105" Pull-Type: 135"	Lift-Type: 110" Pull-Type: 145"
Cutter Weight (Without Chain or Rubber Shields)	Lift-Type 1068 lbs.	Lift-Type 1400 lbs.
Blade Tip Speed	540 RPM 14,592 fpm	540 RPM 17,749 fpm 1000 RPM 18,035 fpm
Deck Material Thickness	10 gauge	
Gearbox Oil Type	80-90W EP	
Gearbox Rating H.P.	Center - 100 HP Outboard 60 HP	
H.P. Rating (PTO)	Lift-Type: 45 - 110 Pull-Type: 30 - 110	Lift-Type: 50 - 110 Pull-Type: 35 - 110
Cutting Height	2" - 12"	
Cutting Capacity	1"	
Optional Safety Shields	Front & Rear Chain/ Front & Rear Rubber	
Skids	Replaceable	
Deck Height	9 5/8"	
Blades	1/2" x 4" Heat Treated Free-Swinging Suction Blades	
Stump Jumper	Round Pan 3/16"	
Driveline	Cat 4, w/Equal Angle U-Joint	Cat 4 w/Equal Angle U-Joint or Constant Velocity U-Joint
Driveline Safety Protection	540 rpm - 4 plate slip clutch 1000 rpm - 2 plate slip clutch	
Gearbox (Speed up beveled gears)	540 rpm or 1000 rpm PTO Driven Gearbox Cast Iron Housing, Beveled Gears	
Tailwheel	Lift-Type: 2 ea. 4" x 8" x 15 1/4" Laminated Pull-Type: 2 ea. 6" x 9" x 21" Laminated or 24" Aircraft tires or 15" Automotive Rims	



RCR2596, RCR2510 & RCRM2510 Models

Features	Benefits
Surpassed rugged industry standards	All Land Pride Cutters have been designed and tested and meet rigorous voluntary testing procedures specified by ANSI.
540 or 1000 RPM	Fits wider variety of tractors. (RCR2596 is 540 RPM only)
5 Year gearbox warranty	Shows our confidence in the gearbox integrity.
3 Gearboxes	Allows equal torque to be spread to left and right gearbox.
Gearbox HP rating	120 Horsepower on splitter gearbox and 60 HP on outboard gearboxes.
Splined rubber flex- couplers between the center and outboard gearboxes	Protects the driveline and gearboxes from hard objects in the blade path.
Constant Velocity U-Joint option on RCR2510 & RCRM2510 Pull-type	Reduces chatter and extends life of U-joint during turns.
Slip-clutch protection on main driveline	Slip-clutch is more convenient than shear-bolt, protects gearbox against sudden impact.
3-Point or Pull-type	Pull-type fits older tractors without a top link or smaller tractors without enough lift capacity. (RCR2596 3-point: Cat. 1 & 2) (RCR2510 & RCRM2510 3-point: Cat. 2 & 3)
High productive cutting width	RCR2596 cuts 8'-0" width. RCR2510 & RCRM2510 cuts 9'-10" width.
Fully welded 10 Gauge deck	Fully welded deck adds rigidity.
3/16" Sidewall thickness	Protects sidewalls from thrown objects.
Obstacle free underside	Underside of deck is free of reinforcement members which tend to allow material to lodge.
Round back design	Allows for cleaner and efficient discharge of material, helps eliminate damage to rear corners by not sticking out.
Chain or rubber shields	Reduces flying debris.
Full length skids with replaceable shoes	Adds reinforcement to side panels. Replaceable shoes allows for change before wearing through to weld-on piece.
Dual leveling rods on Pull-type	Dual leveling rods eliminate deck twisting when going over uneven terrain.
3/16" Round stump jumper	Standard stump jumper aids in sliding over obstructions, which helps protect gearbox output shaft.
1" x 4" Blade bar	Heavy-duty blade bar adds support to stump jumper as well as gearbox output shaft.
Splined blade hub	Splined blade hub offers tight non-slipping attachment to output shaft.
1/2" x 4" Heat-treated blades	Heat-treated blades last longer than non-heat-treated blades.
1" Diameter cutting capacity	Aids in cutting small brush.
High Blade tip speed	RCR2596 (540 rpm) = 14,792 fpm RCR2510 (540 rpm) = 17,749 fpm RCRM2510 (1000 rpm) = 18,035 fpm Means Cleaner Cutting of material.
Laminated tires	Laminated tires can handle almost any condition.
Airplane tires (Pull-Type only)	Airplane tires offer smooth roadability.
Fits Land Pride Quick Hitch	Allows for quick and easy one person hook-up.

Section 7: Troubleshooting

Problem	Cause	Solution
Oil seal leaking	Gearbox overfilled	Drain to side plug hole
	Seals damaged	Replace seals
	Grass or wire wrapped on shaft in seal area	check seal areas daily
Driveline yoke or cross failing	Shock load	Avoid hitting solid objects
	Needs lubrication	Lubricate every 8 hours
Driveline clutch slipping	Scalping the ground	Raise cutting height
	Cutting too fast	Reduce travel speed
	PTO being engaged too fast at high engine rpm	Slowly engage PTO at low engine rpm
	Cutting over solid objects	Avoid solid objects
Bent Driveline (NOTE: driveline should be repaired or replaced if bent)	Contacting frame	Reduce lift height in transport position
	Contacting drawbar	Reposition drawbar
	Bottoming out	Shorten driveline
Driveline telescoping tube failing	Shock load	Avoid hitting solid objects
Driveline telescoping tube wearing	Needs lubrication	Lubricate every 20 hours
Blades wearing excessively	Cutting on sandy ground	Raise cutting height
	Contacting ground frequently	Raise cutting height
Blades breaking	Hitting solid objects	Avoid hitting solid objects
	Blades hitting each other	Blade carriers need to be timed
Blades coming loose	Blades not tightened properly	Tighten blade hardware refer to "Service Cutting Blades" on page 28.
	Improper deck attitude	Lower front of deck, see page 22
Blade carrier becomes loose	Running loose in the past	Replace gearbox output shaft and blade carrier
	Blade carrier hardware not tight enough	Tighten to specified torque
Blade bolt holes worn	Blade hardware running loose	Replace blades and blade bolts if worn
Blade carrier bent	Hitting solid objects	Avoid hitting solid objects and replace blade carrier
Excessive side skid wear	Cutting height not level	Adjust cutter height
	Soil abrasive	Adjust cutter height
	Cutting too low	Adjust cutter height
Tail wheel support failing	Lowering too fast	Adjust rate of drop
	Hitting objects when turning	Reduce speed on turns
Excessive vibration	Driveline bent	Replace driveline
	Blades loose	Tighten blade bolts
	Blade carrier bent	Replace blade carrier
	Blade broken	Replace blade
	Blade will not swing	Remove and inspect blade
	Blades have unequal weight	Replace both blades

Torque Values Chart for Common Bolt Sizes													
Bolt Size (Inches)	Bolt Head Identification						Bolt Size (Metric)	Bolt Head Identification					
	Grade 2		Grade 5		Grade 8			Class 5.8		Class 8.8		Class 10.9	
in-tpi ¹	N ·	ft-lb ³	N · m	ft-lb	N · m	ft-lb	mm x	N · m	ft-lb	N · m	ft-lb	N · m	ft-lb
1/4" - 20	7.4	5.6	11	8	16	12	M 5 X 0.8	4	3	6	5	9	7
1/4" - 28	8.5	6	13	10	18	14	M 6 X 1	7	5	11	8	15	11
5/16" - 18	15	11	24	17	33	25	M 8 X 1.25	17	12	26	19	36	27
5/16" - 24	17	13	26	19	37	27	M 8 X 1	18	13	28	21	39	29
3/8" - 16	27	20	42	31	59	44	M10 X 1.5	33	24	52	39	72	53
3/8" - 24	31	22	47	35	67	49	M10 X 0.75	39	29	61	45	85	62
7/16" - 14	43	32	67	49	95	70	M12 X 1.75	58	42	91	67	125	93
7/16" - 20	49	36	75	55	105	78	M12 X 1.5	60	44	95	70	130	97
1/2" - 13	66	49	105	76	145	105	M12 X 1	90	66	105	77	145	105
1/2" - 20	75	55	115	85	165	120	M14 X 2	92	68	145	105	200	150
9/16" - 12	95	70	150	110	210	155	M14 X 1.5	99	73	155	115	215	160
9/16" - 18	105	79	165	120	235	170	M16 X 2	145	105	225	165	315	230
5/8" - 11	130	97	205	150	285	210	M16 X 1.5	155	115	240	180	335	245
5/8" - 18	150	110	230	170	325	240	M18 X 2.5	195	145	310	230	405	300
3/4" - 10	235	170	360	265	510	375	M18 X 1.5	220	165	350	260	485	355
3/4" - 16	260	190	405	295	570	420	M20 X 2.5	280	205	440	325	610	450
7/8" - 9	225	165	585	430	820	605	M20 X 1.5	310	230	650	480	900	665
7/8" - 14	250	185	640	475	905	670	M24 X 3	480	355	760	560	1050	780
1" - 8	340	250	875	645	1230	910	M24 X 2	525	390	830	610	1150	845
1" - 12	370	275	955	705	1350	995	M30 X 3.5	960	705	1510	1120	2100	1550
1-1/8" - 7	480	355	1080	795	1750	1290	M30 X 2	1060	785	1680	1240	2320	1710
1 1/8" - 12	540	395	1210	890	1960	1440	M36 X 3.5	1730	1270	2650	1950	3660	2700
1 1/4" - 7	680	500	1520	1120	2460	1820	M36 X 2	1880	1380	2960	2190	4100	3220
1 1/4" - 12	750	555	1680	1240	2730	2010							
1 3/8" - 6	890	655	1990	1470	3230	2380							
1 3/8" - 12	1010	745	2270	1670	3680	2710							
1 1/2" - 6	1180	870	2640	1950	4290	3160							
1 1/2" - 12	1330	980	2970	2190	4820	3560							
Torque tolerance + 0%, -15% of torquing values. Unless otherwise specified use torque values listed above.													
Blade Bolt Lock Nut			450 ft-lbs										
Blade Carrier Hub Nut			450 ft-lbs Minimum										

¹ in-tpi = nominal thread dia. in inches-threads per inch
² N · m = newton-meters
³ ft-lb= foot pounds
⁴ mm x pitch = nominal thread dia. in millimeters x thread pitch

Tire Inflation Chart	
Tire Size	Inflation PSI
AC Tire, 24" x 7.7"	40

Section 8: Appendix

Warranty

Land Pride warrants to the original purchaser that this Land Pride product will be free from defects in material and workmanship beginning on the date of purchase by the end user according to the following schedule when used as intended and under normal service and conditions for personal use.

Overall Unit and Drivelines: One year Parts and Labor

Gearbox: (S/N 329841+) Five years on Parts and labor.

Hydraulic Cylinder: One year Parts and Labor

Hoses and seals considered wear items

Blades, Tires, and Driveline Friction Discs: Considered wear items.

This Warranty is limited to the replacement of any defective part by Land Pride and the installation by the dealer of any such replacement part, and does not cover common wear items such as blades, belts, tines, etc. Land Pride reserves the right to inspect any equipment or parts which are claimed to have been defective in material or workmanship.

This Warranty does not apply to any part or product which in Land Pride's judgment shall have been misused or damaged by accident or lack of normal maintenance or care, or which has been repaired or altered in a way which adversely affects its performance or reliability, or which has been used for a purpose for which the product is not designed. Misuse also specifically includes failure to properly maintain oil levels, grease points, and driveline shafts.

Claims under this Warranty must be made to the dealer which originally sold the product and all warranty adjustments must be made through such dealer. Land Pride reserves the right to make changes in materials or design of the product at any time without notice.

This Warranty shall not be interpreted to render Land Pride liable for damages of any kind, direct, consequential, or contingent to property. Furthermore, Land Pride shall not be liable for damages resulting from any cause beyond its reasonable control. This Warranty does not extend to loss of crops, any expense or loss for labor, supplies, rental machinery or for any other reason.

No other warranty of any kind whatsoever, express or implied, is made with respect to this sale; and all implied warranties of merchantability and fitness for a particular purpose which exceed the obligations set forth in this written warranty are hereby disclaimed and excluded from this sale.

This Warranty is not valid unless registered with Land Pride within 30 days from the date of purchase by the end user.



Corporate Office: P.O. Box 5060
Salina, Kansas 67402-5060 USA
www.landpride.com
